

EPSON®

STYLUS COLOR II

COLOR INK JET PRINTER

Reference Guide

All rights reserved. No part of this publication may be reproduced, stored in a retrieval system, or transmitted in any form or by any means, electronic, mechanical, photocopying, recording, or otherwise, without the prior written permission of Seiko Epson Corporation. No patent liability is assumed with respect to the use of the information contained herein. Neither is any liability assumed for damages resulting from the use of the information contained herein.

Neither Seiko Epson Corporation nor its affiliates shall be liable to the purchaser of this product or third parties for damages, losses, costs, or expenses incurred by purchaser or third parties as a result of: accident, misuse, or abuse of this product or unauthorized modifications, repairs, or alterations to this product, or (excluding the U.S.) failure to strictly comply with Seiko Epson Corporation's operating and maintenance instructions.

Seiko Epson Corporation shall not be liable against any damages or problems arising from the use of any options or any consumable products other than those designated as Original EPSON Products or EPSON Approved Products by Seiko Epson Corporation.

EPSON, EPSON Stylus, and EPSON ESC/P are registered trademarks and EPSON ESC/P 2 is a trademark of Seiko Epson Corporation.

EPSON Connection is a service mark of Epson America, Inc.

Windows printer driver copyright Software 2000 Ltd Oxford, England. Portions copyright Seiko Epson Corporation.

General Notice: Other product names used herein are for identification purposes only and may be trademarks of their respective owners. EPSON disclaims any and all rights in those marks.

The Energy Star emblem does not represent EPA endorsement of any product or service.

Copyright © 1995 by Epson America, Inc.

10/95



Printed on recycled paper with at least 10% post-consumer content

FCC Compliance Statement For United States Users

This equipment has been tested and found to comply with the limits for a Class B digital device, pursuant to Part 15 of the FCC Rules. These limits are designed to provide reasonable protection against harmful interference in a residential installation. This equipment generates, uses, and can radiate radio frequency energy and, if not installed and used in accordance with the instructions, may cause harmful interference to radio or television reception. However, there is no guarantee that interference will not occur in a particular installation. If this equipment does cause interference to radio and television reception, which can be determined by turning the equipment off and on, the user is encouraged to try to correct the interference by one or more of the following measures.

- Reorient or relocate the receiving antenna.
- Increase the separation between the equipment and receiver.
- Connect the equipment into an outlet on a circuit different from that to which the receiver is connected.
- Consult the dealer or an experienced radio/TV technician for help.

WARNING

The connection of a non-shielded equipment interface cable to this equipment will invalidate the FCC Certification of this device and may cause interference levels which exceed the limits established by the FCC for this equipment. It is the responsibility of the user to obtain and use a shielded equipment interface cable with this device. If this equipment has more than one interface connector, do not leave cables connected to unused interfaces. Changes or modifications not expressly approved by the manufacturer could void the user's authority to operate the equipment.

For Canadian Users

This digital apparatus does not exceed the Class B limits for radio noise emissions from digital apparatus as set out in the radio interference regulations of the Canadian Department of Communications.

Le présent appareil numérique n'émet pas de bruits radioélectriques dépassant les limites applicables aux appareils numériques de Classe B prescrites dans le règlement sur le brouillage radioélectrique édicté par le Ministère des Communications du Canada.

Contents

Introduction

Energy Star Compliance	1
Energy-saving Tips	2
How to Use This Manual	2
Where to Get Help	3
Electronic Support Services	4
Important Safety Instructions	6

Chapter 1 Paper Handling

Choosing Paper and Other Media	1-2
Setting the Paper Thickness and Adjustment Levers	1-3
Setting the Paper Thickness Lever	1-3
Setting the Thickness Adjustment Lever	1-4
Loading Plain Paper	1-5
Loading Special Papers and Other Media	1-7
Loading Special Papers and Transparencies	1-8
Loading Envelopes	1-10

Chapter 2 Controlling the Printer

Using the Printer's Control Panel	2-2
Lights	2-3
Buttons	2-4
Using the Default Setting Mode	2-7

Chapter 3 Maintenance

Cleaning the Print Heads	3-2
Replacing Ink Cartridges	3-3
Selecting the Correct Ink Cartridges	3-4
Removing and Installing Ink Cartridges	3-5
Cleaning the Printer	3-8
Transporting the Printer	3-9
Calibrating the Printer When Printing from DOS	3-10

Chapter 4 Troubleshooting

Print Quality Problems	4-2
Problems with Printing	4-6
Paper Handling Problems	4-12
Paper Jam Problems	4-12
Paper Feeding Problems	4-12
Other Paper Handling Problems	4-13

Appendix A Technical Specifications

Printing	A-2
Paper	A-3
Ink Cartridges	A-5
Mechanical	A-6
Electrical	A-7
Environmental	A-7
Safety Approvals	A-7
Fonts	A-8
Interface Specifications	A-9
Parallel Interface	A-9
Serial Interface	A-11
Initialization	A-12
Default Settings	A-13

Appendix B Commands and Character Tables

Command List	B-2
EPSON ESC/P 2 Commands	B-2
IBM X24/X24E Emulation Codes	B-3
Character Tables	B-4
International Character Sets	B-8
Characters Available with ESC (^ Command	B-9

Glossary

Index

Printer Parts

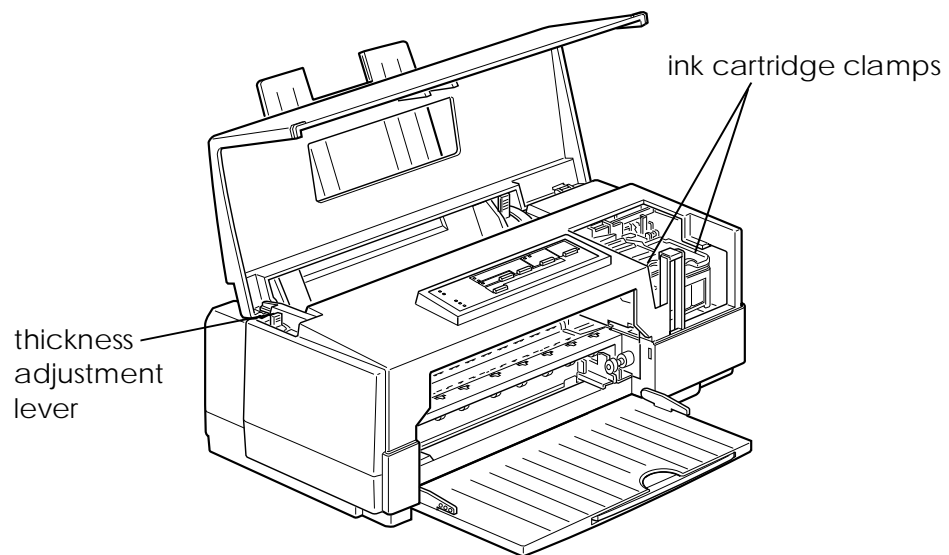
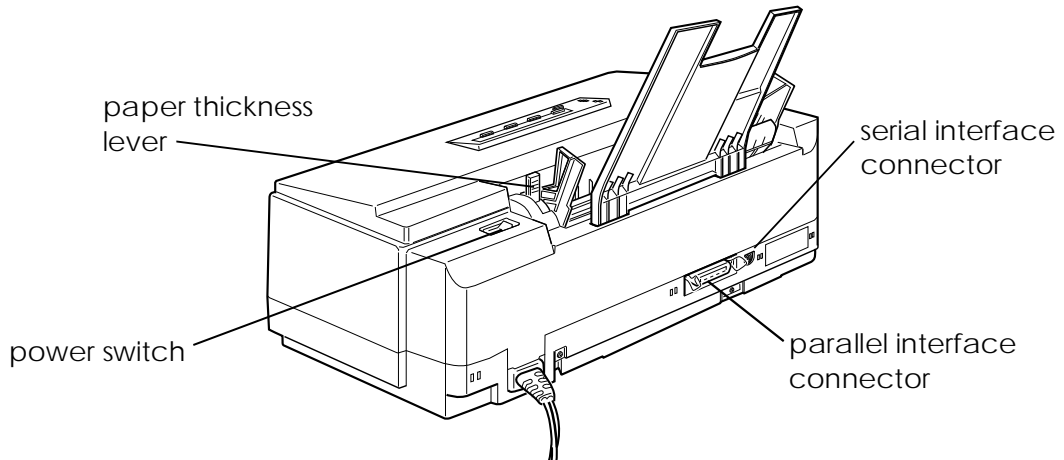
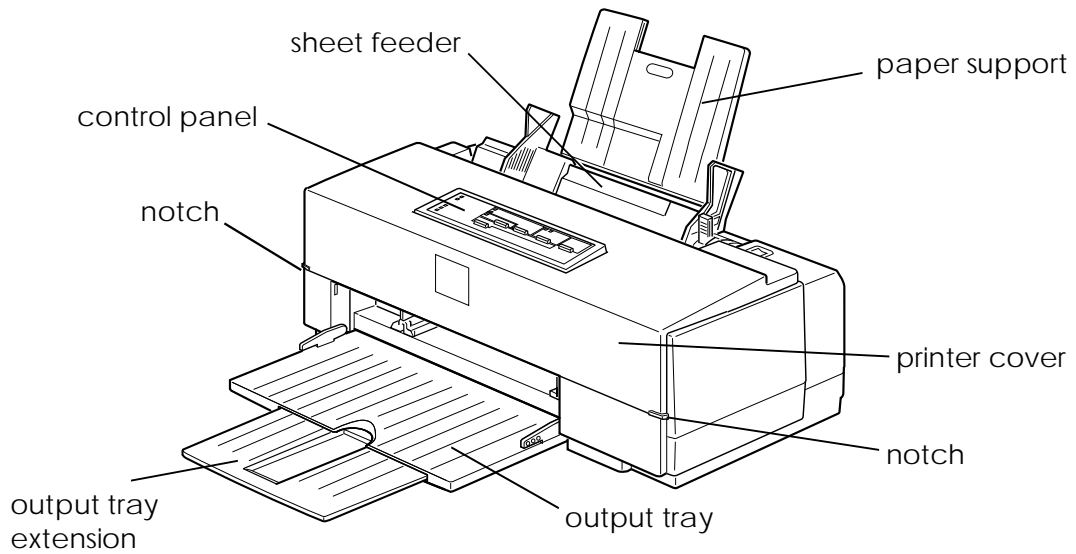

Introduction

This manual contains general operating and maintenance instructions for your EPSON® Stylus® COLOR II, as well as troubleshooting guidelines and technical specifications. For instructions on setting up your printer and using the Microsoft® Windows® or Apple® Macintosh® printer driver, see the appropriate *Setup and Software Guide*.

Note:

After you install the driver, check the ReadMe icon in the EPSON group in Windows or on the Macintosh hard disk for the latest information about your printer and software.

Your printer supports a wide variety of settings that give you the flexibility to improve print quality or speed up printing. Using the printer driver software (described in the *Setup and Software Guide*), you can control settings such as document type, printing mode, and halftoning to produce just the right effects in your printed documents.

To make your job easy, both the Windows and Macintosh printer drivers include an option that analyzes the elements on a page to be printed and automatically adjusts the driver settings so your printed results are appropriate for the image type. See the *Setup and Software Guide* for complete instructions on using the driver and for color print samples of the kinds of output the printer can produce.



Energy Star Compliance

As an Energy Star Partner, EPSON has determined that this product meets the Energy Star guidelines for energy efficiency.

The EPA estimates that if all desktop computers, printers, and other peripheral devices met Energy Star standards, energy cost savings would exceed \$1 billion annually and carbon dioxide emissions would be reduced by 20 million tons.

All of EPSON's ink jet printers conform to Energy Star standards.

Energy-saving Tips

Here are a few tips you can use to be even more energy-wise:

- ❑ If your monitor isn't Energy Star compliant, turn it off when you're not using it.
- ❑ Turn off your computer, printer, and monitor each day when you are done using them.
- ❑ Use the print preview option in your software before you print something so you can catch errors before you commit them to paper.
- ❑ If you have an electronic mail system available to you, send E-mail rather than memos. Not only is this faster, but you'll save paper and storage space too.

How to Use This Manual

After you have set up the printer as described in the *Setup and Software Guide*, refer to this manual for the following information:

Chapter 1, "Paper Handling," explains how to select the right paper for your print job and load special paper and other media in your printer.

Chapter 2, “Controlling the Printer,” provides instructions for managing the printer’s operation through its control panel. It also explains how to access the printer’s Default setting mode.

Chapter 3, “Maintenance,” contains instructions for cleaning the print heads, replacing the ink cartridges, cleaning and transporting the printer, and calibrating the printer from DOS.

Chapter 4, “Troubleshooting,” contains troubleshooting guidelines for any print quality and printer operation problems you may have.

Appendix A, “Technical Specifications,” gives the specifications for the Stylus COLOR II printer.

Appendix B, “Commands and Character Tables,” lists the EPSON ESC/P 2™ and IBM® X24/X24E emulation commands supported by the printer and shows the printer’s built-in character tables.

A **Glossary** and **Index** are provided at the end of the manual.

Where to Get Help

If you purchased your printer in the United States or Canada and you need technical assistance you can call an EPSON Color Specialist at (800) 788-0343.

EPSON also provides customer support and service through a network of Authorized EPSON Customer Care Centers and provides the following services when you dial **(800) 922-8911**:

- EPSON technical information library fax service
- Product literature on current and new products
- Assistance in locating your nearest Authorized EPSON Reseller or Customer Care Center

- ❑ Technical information on the installation, configuration, and operation of EPSON products
- ❑ Customer relations.

You can purchase ink cartridges, paper, parts, printed manuals, and accessories for EPSON products from EPSON Accessories at **(800) 873-7766** (U.S. sales). In Canada, call **(800) BUY-EPSON** for sales locations.

If you purchased your printer outside the United States or Canada, contact your EPSON dealer or the marketing location nearest you for customer support and service.

If you need help with any software program you are using, see that program's documentation for technical support information.

Electronic Support Services

If you have a modem, the fastest way to access helpful tips, specifications, drivers, application notes, DIP switch or jumper settings, and bulletins for EPSON products is through the online services below.

World Wide Web

If you are connected to the Internet and have a Web browser, you can access EPSON's World Wide Web site at <http://www.epson.com>. EPSON's home page links users to What's New, EPSON Products, EPSON Connection,SM Corporate Info and EPSON Contacts. Link to the EPSON Connection for the latest drivers and FAQs (Frequently Asked Questions) and the EPSON Chat area. To get in touch with EPSON around the world, EPSON Contacts includes Contact Information for local EPSON subsidiaries.

EPSON Bulletin Board Service

You can call the EPSON Bulletin Board Service (BBS) at (310) 782-4531. No membership is required. Make sure your communications software is set to 8 data bits with 1 stop bit, no parity bit, and a modem speed of 28.8 Kbps or less. See the documentation that came with your communications software for more information.

CompuServe online support

CompuServe® members can call the Epson America Forum on CompuServe. If you are already a member, simply type GO EPSON at the menu prompt to reach the Forum.

If you are not currently a member, you are eligible for a free introductory membership as an owner of an EPSON product.

This membership entitles you to:

- An introductory credit on CompuServe
- Your own user ID and password
- A complimentary subscription to *CompuServe Magazine*, CompuServe's monthly publication.

To take advantage of this offer, call **(800) 848-8199** in the United States and Canada and ask for representative #529. In other countries, call the following U.S. telephone number: **(614) 529-1611**, or your local CompuServe access number.

Important Safety Instructions

Before using your printer, read the following safety instructions to make sure you use the printer safely and effectively.

- ❑ Turn off and unplug the printer before cleaning. Clean with a damp cloth only. Do not spill liquid on the printer.
- ❑ Do not place the printer on an unstable surface or near a radiator or heat register.
- ❑ Do not block or cover the openings in the printer's cabinet or insert objects through the slots.
- ❑ Use only the type of power source indicated on the printer's label.
- ❑ Connect all equipment to properly grounded power outlets. Avoid using outlets on the same circuit as photocopiers or air control systems that regularly switch on and off.
- ❑ Do not let the power cord become damaged or frayed.
- ❑ If you use an extension cord with the printer, make sure the total ampere rating of the devices plugged into the extension cord does not exceed the cord's ampere rating. Also, make sure the total of all devices plugged into the wall outlet does not exceed 15 amperes.
- ❑ Except as specifically explained in this *Reference Guide*, do not attempt to service the printer yourself.
- ❑ Unplug the printer and refer servicing to qualified service personnel under the following conditions:

If the power cord or plug is damaged; if liquid has entered the printer; if the printer has been dropped or the cabinet damaged; if the printer does not operate normally or exhibits a distinct change in performance. Adjust only those controls that are covered by the operating instructions.

Chapter 1

Paper Handling

1

Choosing Paper and Other Media	1-2
Setting the Paper Thickness and Adjustment Levers	1-3
Setting the Paper Thickness Lever	1-3
Setting the Thickness Adjustment Lever	1-4
Loading Plain Paper	1-5
Loading Special Papers and Other Media	1-7
Loading Special Papers and Transparencies	1-8
Loading Envelopes	1-10

Read this chapter for information about choosing the best paper or other media for your printing needs and for instructions on loading them in your printer.

Choosing Paper and Other Media

You can use most plain paper with your printer and achieve good results. Coated papers give you better results because they reduce the amount of ink that is absorbed. However, if the coated paper does not absorb enough ink, the ink can smear.

To ensure the best results, EPSON provides special papers and transparencies that are formulated for the inks used in EPSON ink jet printers. These papers include the following:

- ❑ **EPSON special coated paper for 360 dpi.** Use this paper for best results when printing at 360 dpi.
- ❑ **EPSON special coated paper for 720 dpi.** Use this paper for best results when printing at 720 dpi. Five sample sheets are included with the printer.
- ❑ **EPSON high-quality glossy paper.** Use this paper with 720 dpi to produce camera-ready composites. When printing on glossy paper, use only EPSON high-quality glossy paper.
- ❑ **EPSON transparency film.** When printing transparencies, use only EPSON transparencies. For best results, use transparencies within six months of opening the package. Do not use 720 dpi when printing transparencies.

To order EPSON papers and transparencies, contact your dealer or call EPSON Accessories at (800) 873-7766 (U.S. only). In Canada, call (800) BUY-EPSON for sales locations.

Use the following part numbers when ordering:

Paper or other media	Size	Part number
Special coated paper for 720 dpi	Letter (8.5 × 11 inches)	S041062
	Legal (8.5 × 14 inches)	S041048
Special coated paper for 360 dpi	Letter (8.5 × 11 inches)	S041060
High-quality glossy paper	Letter (8.5 × 11 inches)	S041072
Transparency film	Letter (8.5 × 11 inches)	S041064

Setting the Paper Thickness and Adjustment Levers

Before you start printing, you should check the paper thickness and adjustment levers to make sure they are set correctly for the type of paper or other media you are loading.

C ***Caution:*** *Before you change the lever settings, make sure there is no paper in the paper path and that printing is paused. To do this, press the Pause button or turn off the printer.*

Setting the Paper Thickness Lever

The paper thickness lever on the right side of the sheet feeder has two settings: plain paper and thick paper. Set the lever to the position that best suits the paper or other media you plan to use, as shown in the following table and illustration.

Paper type	Paper thickness lever position
Standard paper	Plain paper
Transparency film	Plain paper
Envelopes or labels	Thick paper

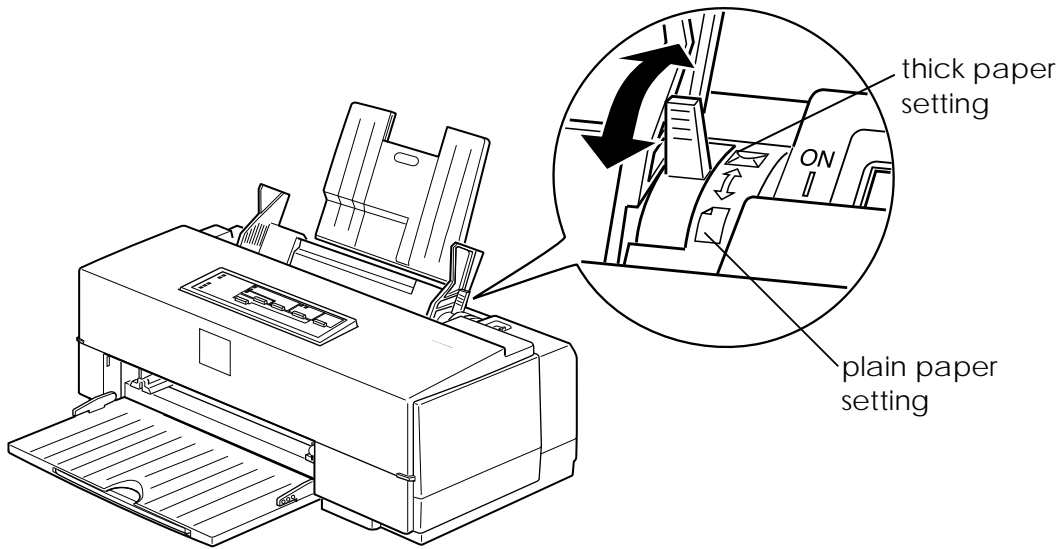

Setting the Thickness Adjustment Lever

Use the table below to set the thickness adjustment lever for your media type.

Paper type	Thickness adjustment lever position
Standard paper	0
Transparency film	0
Envelopes or labels	+
Previously smeared documents	+

If a document is smeared, set the thickness adjustment lever to the + position (regardless of the paper type) and print it again.

To access the lever, open the printer cover; the lever is in the left back corner, as shown in the following illustration.

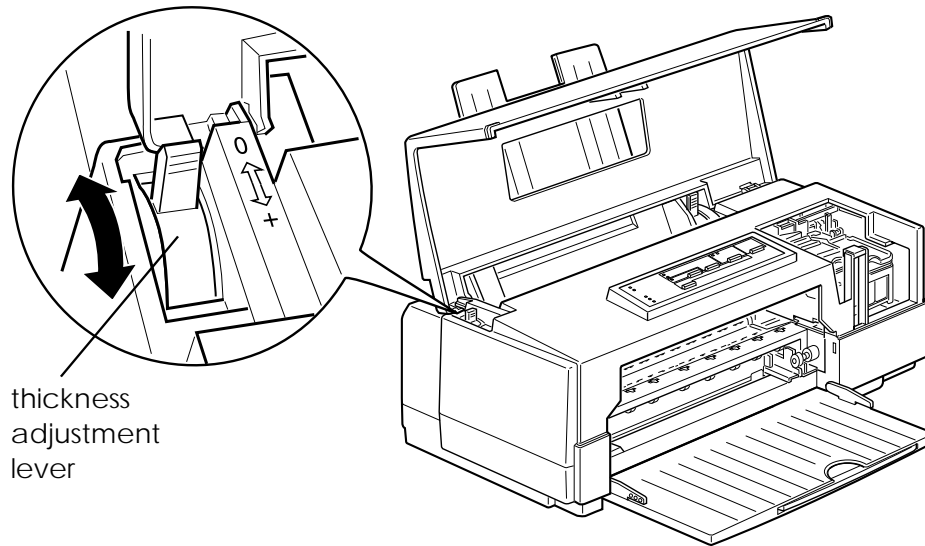

Loading Plain Paper

The following procedure explains how to load plain bond paper. For instructions on loading coated or glossy paper, envelopes, and transparencies, see page 1-7.

You can load up to 100 sheets of plain paper. For paper specifications, see Appendix A.

Always load plain paper with the printable surface facing upward. The printable surface is marked with an arrow on most plain paper packaging.

Note:

You can use these instructions for printing on labels; however, be sure to set the paper thickness lever to the Thick paper position and the thickness adjustment lever to the + position. Also make sure no labels are curled or peeling away from the backing when you load them.

1. Lower the output tray at the front of the printer. Then slide out the extension.

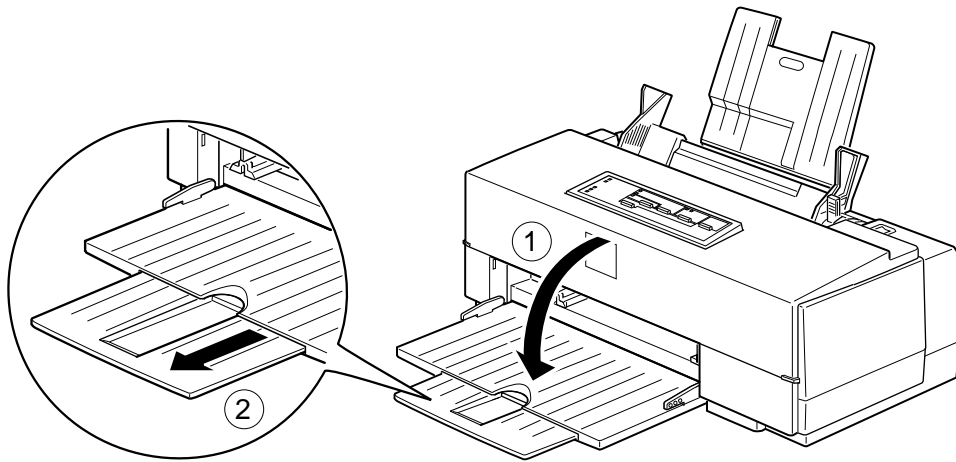

2. Slide the left edge guide on the sheet feeder to the left as far as it will go.

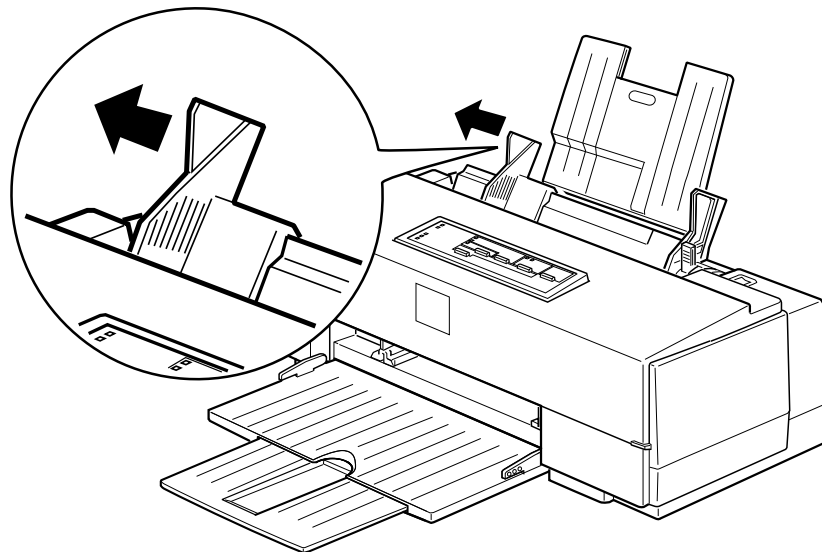

3. Fan a stack of paper; then tap it on a flat surface to even the edges.

4. Load the stack of paper, printable side up, so that its right edge is firmly against the right side of the sheet feeder. (Do not load paper above the arrow printed on the inside of the left edge guide on the sheet feeder.) Then slide the left edge guide against the left edge of the paper.

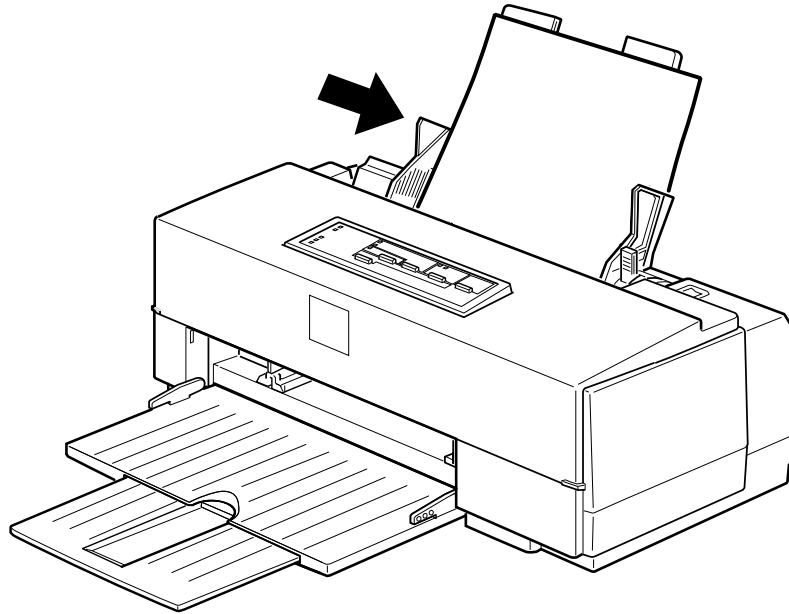

5. Change the Media Type and other printer driver settings so they are appropriate for the paper or labels you loaded. For instructions see your *Setup and Software Guide*. (For labels select Plain paper as your Media Type.)

Loading Special Papers and Other Media

When using special coated paper, glossy paper, transparencies, or envelopes, keep the following in mind:

- Use special coated paper and glossy paper within one year of purchase. Use transparencies within six months.
- Do not touch the printable surface of the paper; hold the sheets by their edges. The moisture and oils on your hands can reduce print quality.

- ❑ After printing on high-quality glossy paper or transparencies, remove each sheet from the output tray immediately. Make sure each sheet is dry before stacking.
- ❑ You can print on sheets of labels in your printer; just follow the instructions for loading plain paper on page 1-5.
- ❑ Return unused sheets and envelopes to their original package as soon as possible after you finish printing. Unfavorable storage conditions—especially high temperature, humidity, and direct sunlight—can damage the media.
- ❑ Follow any other special loading procedures included in the rest of this section.

Loading Special Papers and Transparencies

The following procedure explains how to load coated papers, glossy paper, and transparencies. You can load up to the following number of sheets in the sheet feeder:

- ❑ 70 sheets of special coated paper

Note:

If you load legal-size special coated paper for 720 dpi, do not load it more than halfway to the arrow on the left edge guide of the sheet feeder.

- ❑ 50 sheets of transparency film with one sheet of plain paper beneath the last transparency in the stack
- ❑ 30 sheets of high-quality glossy paper with a sheet of plain paper beneath the last sheet in the stack; to avoid printing on the plain paper, print your document one page at a time. If you load a single sheet of glossy paper, place a sheet of plain paper beneath it and print one page at a time.

Note:

If you load multiple sheets of glossy paper, the minimum top margin is 1.2 inches (30 mm). To print with a smaller top margin, load and print glossy paper one sheet at a time.

Follow these steps to load special paper or transparency film:

1. Lower the output tray at the front of the printer and slide out the extension.

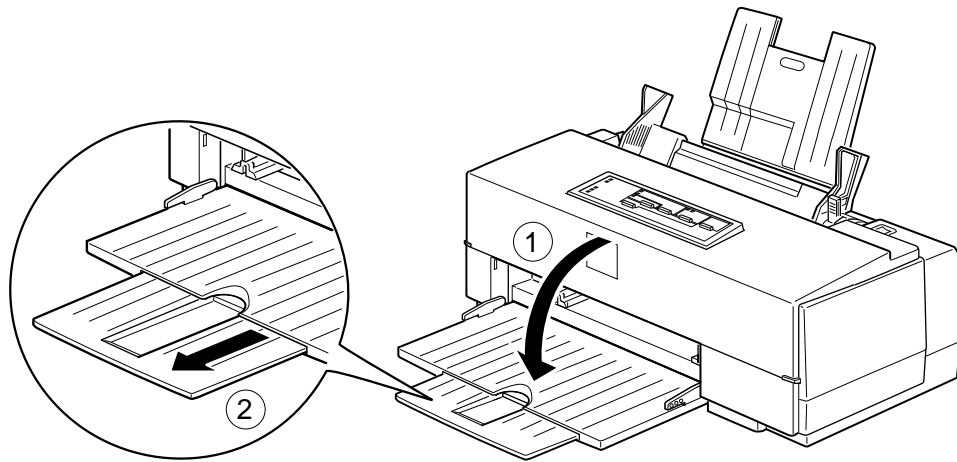

2. Slide the left edge guide on the sheet feeder to the left as far as it will go.

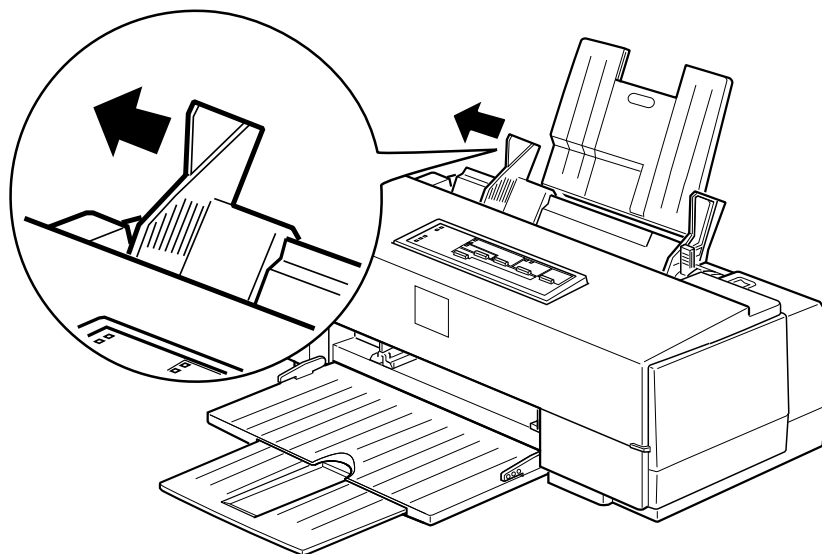

3. Prepare the paper or transparency film as described on the previous page.
4. If you are loading a stack of paper or transparencies, fan the stack and then tap it on a flat surface to even the edges.
5. Before you load paper, make sure the printable surface faces up. For coated papers, the printable side is whiter than the other side. For glossy paper and transparencies, the printable side is face up when the cut corner is positioned as shown in the illustration below.

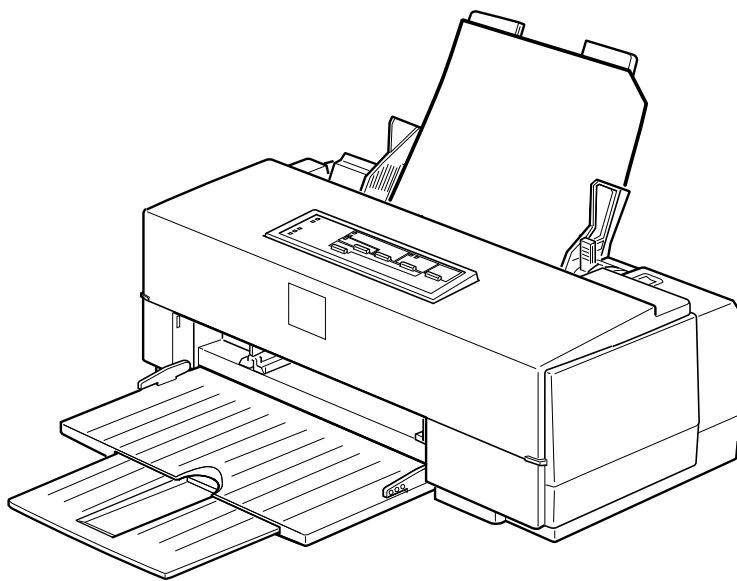

6. Change the Media Type and other printer driver settings so they are appropriate for the paper or transparency film you loaded. (For instructions, see your *Setup and Software Guide*.)

Loading Envelopes

For detailed specifications on the thickness and weight of the envelopes you can load, see Appendix A. Do not use envelopes that are curled or folded, or ones that are too thin; they may curl during printing. Also, do not choose 720 dpi resolution for envelope printing.

Follow these steps to load envelopes:

1. Make sure you set the paper thickness and thickness adjustment levers to the correct positions for envelope printing, as described on page 1-3.
2. You can load up to 10 envelopes in the sheet feeder with the printable side facing up as shown.

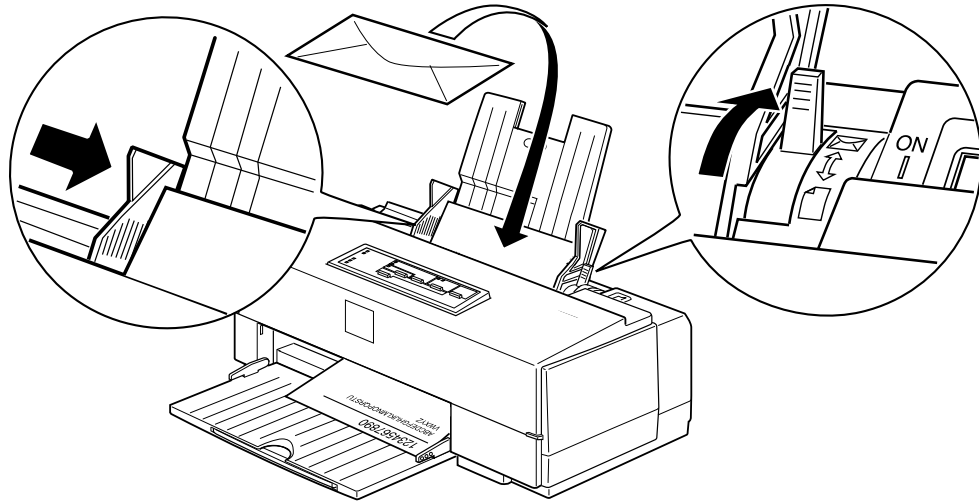

3. Adjust the left edge guide so the envelopes feed straight into the paper path.
4. Change the Media Type and other printer driver settings so they are appropriate for the envelopes you loaded. (For instructions, see your *Setup and Software Guide*.)

Chapter 2

Controlling the Printer

Using the Printer's Control Panel	2-2
Lights	2-3
Buttons	2-4
Using the Default Setting Mode	2-7



This chapter explains how to control the printer using the control panel. It also describes the additional printer functions you can perform using the Default setting mode.

Using the Printer's Control Panel

The printer's control panel contains lights for displaying the printer status and buttons for controlling certain functions, as described in this section.

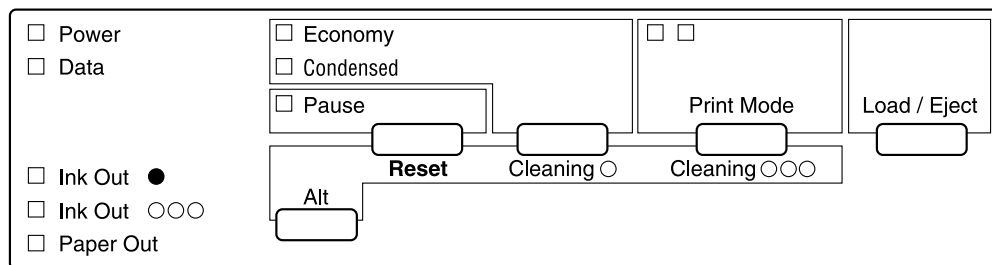

Since most printer settings can be controlled from your software, you do not often need to use the control panel. Normally you need to use it only to do the following:

- Clean the black or color print heads
- Replace the ink cartridges
- Pause the printer temporarily
- Turn on economy or condensed mode
- Change the printer's default settings
- Reset the printer.

Lights

Power	On when the printer is on.
Data	Flashes when data is being received by the printer. On when data remains in printer memory or when printing a self test or demonstration page.
Ink Out 0	Flashes when the black ink cartridge is low on ink. On when the black ink cartridge is empty or not installed. The printer will not work if the black ink cartridge is empty or not installed.
Ink Out NNN	Flashes when the color ink cartridge is low on ink. On when the color ink cartridge is empty or not installed. The printer will not work if the color ink cartridge is not installed. If color ink runs out while you're printing, the printer stops. You can continue to print with the black ink cartridge by switching to monochrome printing. To do this, turn off the printer, turn it on again, and resend your print job.
Paper Out	On when the printer runs out of paper. Flashes rapidly if there is a paper jam.
Economy	On when economy printing mode is selected. In economy mode the printer uses less ink by printing fewer dots per character. It also makes black printing appear gray. Use this mode for rough drafts of text only that are printed from DOS applications.
Condensed	On when condensed mode is selected. The printer prints selected fonts at 60% of their width so more characters fit on a page. (Software can override this setting.)

Pause On when printing is paused and flashes when you clean the print heads or replace ink cartridges. The Pause light also flashes when an error occurs. Never turn off the printer when the Pause light is flashing.

Print Mode See Print Mode in the next section.

Buttons

In addition to the button functions explained below, you can perform additional functions using certain button combinations and power-on sequences, as described on page 2-5.

Alt Used alone or in combination with other buttons to reset the printer, clean the print heads, or replace the ink cartridges; see the next section for more information.

Pause (or Reset) Stops printing temporarily. Press it again to resume.

Economy/Condensed (or Cleaning 0) Selects economy or condensed mode as indicated by the Economy and Condensed lights. Use this button only if you print from a DOS application.

Print Mode (or Cleaning NNN)

Selects the paper and ink type when using DOS. The current setting is indicated by the left and right Print Mode lights, described in the following table.

Paper type	Left light	Right light
Plain paper (true black)	Off	Off
Plain paper (composite black)	Off	On
Coated or glossy paper	On	Off
Transparency film	On	On

For most printing on plain paper, select Plain paper (true black). If the black ink on the printout is blurred, select Plain paper (composite black). Composite black is produced by mixing cyan, magenta, and yellow ink.

Load/Eject Loads or ejects a sheet of paper. The printer normally loads and ejects paper automatically.

Button combinations and power-on functions

The button combinations below perform additional functions to control your printer.

Alt + Pause (or Reset)

Clears the printer's buffer and resets the printer settings to their factory defaults; see "Initialization" in Appendix A for more information.

Alt + Economy/Condensed (or Cleaning 0)

Cleans the black print head; see "Cleaning the Print Heads" in Chapter 3 for more information.

Alt + Print Mode (or Cleaning NNN)

Cleans the color print head; see “Cleaning the Print Heads” in Chapter 3 for more information.

Load/Eject + POWER switch

Checks the paper length and performs a printer self test. Hold down Load/Eject until the printer feeds a page. See “Testing the Printer” in Chapter 1 of your *Setup and Software Guide* for more information.

Load/Eject + Print Mode + POWER switch

When connected to a PC, prints a page containing a hexadecimal representation (hex dump) of the data sent to the printer for troubleshooting use; see Chapter 4. Hold down Load/Eject and Print Mode until the printer feeds a page. To exit hex dump mode, press the Pause button and turn off the printer. (If a partial page feeds before you press Pause, press Load/Eject to clear the paper path.)

Alt + POWER switch

Prints a demonstration page of the printer’s fonts and colors. (Paper must be loaded in the printer.) Hold down Alt until the printer feeds a page. To exit demonstration mode, wait until the Pause light comes on; then turn off the printer.

Economy/Condensed + POWER switch

Enters the printer’s Default setting mode and prints an instruction page; see the next section for more information. Hold down Economy/Condensed until the printer feeds a page. To exit Default setting mode, press the Pause button and turn off the printer. (If a partial page feeds before you press Pause, press Load/Eject to clear the paper path.)

Pause + POWER switch

Enters printer adjustment mode and prints a multilingual instruction sheet on calibrating the printer. (Paper must be loaded in the printer.) Use this mode only if you are printing from DOS applications. Hold down Pause until the printer feeds a page. To exit printer adjustment mode, press the Pause button and turn off the printer. (If a partial page feeds before you press Pause, press Load/Eject to clear the paper path.)

Using the Default Setting Mode

Additional printer functions are available through the Default setting mode. Because the printer's factory defaults are designed to meet the needs of almost all users, you rarely need to change the printer functions listed below. If necessary, however, you can turn on the Default setting mode and change the settings using the control panel buttons.

- ❑ **Print direction.** Specifies how the print head moves across the page. The options are Uni-D, Bi-D, and Auto (default). When Uni-D is on, the print head prints in only one direction to provide the most precise alignment for graphics and text. In Bi-D printing, the print head prints in both directions. Bi-D is faster but the vertical alignment may not be as precise as Uni-D. When Auto is selected, the printer switches automatically between Uni-D and Bi-D as necessary when it receives data.
- ❑ **Font and Pitch.** Select the built-in printer font and character pitch used as the default. Normally you use your software to select the font and pitch. The default Font and Pitch is Courier 10 cpi (characters per inch).

- ❑ **Interface mode.** Determines from which interface the printer receives print data. The default setting, Auto, allows the printer to automatically switch as needed between the parallel and serial interfaces. However, if you experience communication problems, you might want to set the interface mode to either Parallel or Serial.
- ❑ **Auto interface wait time.** Sets the time period for the printer to wait for data from the current interface (and accept no data from the other interface) when you're using the Auto interface mode. You can select a 10-second (default) or 30-second timeout.
- ❑ **Software.** Specifies the printer control language to use: EPSON ESC/P 2 (default) or IBM X24/X24E. If your software allows you to select EPSON ESC/P 2, choose it for the most advanced fonts and graphics.
- ❑ **Auto CR.** Specifies that the printer perform a carriage return and line feed operation if the print positions exceed the right margin of the paper. (Used in IBM X24/X24E mode only.)
- ❑ **AGM (Alternate Graphics Mode).** Specifies that the printer use high-resolution, 24-pin graphics commands. (Used in IBM X24/X24E mode only.)
- ❑ **Character table.** Selects the set of characters and symbols that can be printed. The default is the Italic U.S.A. character table. If you commonly use a language containing accents, symbols, or other characters not available in the Italic U.S.A. character table, change to a different character table. For a list of the character tables, see Appendix B.
- ❑ **Auto line feed.** Specifies that a carriage return character encountered in the print file be accompanied by a line feed command. By default, auto line feed is off. If text lines print on top of one another, turn on auto line feed.

- ❑ Network interface mode. If you're having trouble printing when the printer is connected to multiple computers, turn on network interface mode. By default, network interface mode is off.
- ❑ Loading position. Determines the top margin by defining how close to the paper edge the first line can print. The loading position can be 3 mm (default) or 8.5 mm. Normally you should use your software to adjust your top margin.
- ❑ Thick paper. Select Index card (portrait) or Envelope (default) if you print on these media.

To turn on Default setting mode and print instructions, turn off the printer. Then hold down the Economy/Condensed button while you turn the printer back on. Follow the instructions the printer prints to change the default settings by pressing the buttons on the control panel. When you are finished, press Pause and turn off the printer to exit Default setting mode. (If a partial page feeds before you press Pause, press Load/Eject to clear the paper path.)

Chapter 3

Maintenance

Cleaning the Print Heads	3-2
Replacing Ink Cartridges	3-3
Selecting the Correct Ink Cartridges	3-4
Removing and Installing Ink Cartridges	3-5
Cleaning the Printer	3-8
Transporting the Printer	3-9
Calibrating the Printer When Printing from DOS	3-10



Instructions in this chapter tell you how to do the following to maintain and care for your printer:

- Clean the print heads
- Replace the ink cartridges
- Clean the printer
- Transport the printer
- Calibrate the printer when printing from DOS.

Cleaning the Print Heads

The printer periodically cleans its print heads automatically, so normally you should not need to manually activate a cleaning cycle. However, if print quality diminishes, you can run a cleaning cycle to unclog the print head nozzles so they deliver ink properly.

You can clean one or both print heads. Each cleaning cycle takes about one minute, during which the carriage moves and you hear the printer recharging the print heads. The Pause light flashes throughout the cleaning cycle and then stays on when the cycle is finished.

To clean the color print head:

1. Make sure the printer is turned on and press the Pause button.
2. Hold down the Alt button and press Print Mode. The cleaning cycle begins.
3. Press the Pause button.

To clean the black print head:

1. Make sure the printer is turned on and press the Pause button.
2. Hold down the Alt button and press Economy/Condensed. The cleaning cycle begins.
3. Press the Pause button.

After you clean the print heads, turn off the printer; then hold down the Alt button as you turn the printer back on. This prints a demonstration page so you can see if your print quality has improved. (After the page prints, the Pause light comes on; turn off the printer to exit demonstration mode.)

It can sometimes take up to five cleaning cycles to improve print quality. If the print quality does not improve after you clean the print heads five times (printing a demonstration page to check after each cleaning), and you are sure the cartridges are not low on or out of ink (as described in the next section), contact your dealer or authorized EPSON servicer.

Replacing Ink Cartridges

The printer's Ink Out 0 (black) and Ink Out NNN (color) lights tell you when your ink cartridges are low on ink and when you need to replace them. If one of these lights flashes, the indicated cartridge is low on ink; if it remains on, you need to replace the cartridge.

- C** **Caution:**
- ❑ *Do not replace an ink cartridge unless its Ink Out light tells you to. If you replace a cartridge before its light flashes, the sensor that tells you when ink is out will not work with the new cartridge.*

- ❑ *Leave the old cartridge installed in the printer until you are ready to replace it with a new one. Attempting to print without a cartridge installed can damage the printer.*
- ❑ *If you replace a cartridge when the Data light is on, you must turn off your printer and then turn it back on. This erases the data received by the printer and you must resend your print job.*
- ❑ *Once you install the ink cartridges, do not open the clamps or remove the cartridges except to replace them with new ones. Once you remove a cartridge, you cannot reuse it.*

When the color ink cartridge is empty, you can continue printing with the black ink cartridge by switching to monochrome mode. To do this, turn off the printer, then turn it back on and resend your print job.

If the black ink cartridge is empty, you cannot continue printing, even if the color cartridge still contains ink.

Selecting the Correct Ink Cartridges

Use only these EPSON ink cartridges:

Black ink cartridge	S020047
Color ink cartridge	S020049

When you need new ink cartridges, contact your dealer or call EPSON Accessories at (800) 873-7766 (U.S. only). In Canada, call (800) BUY-EPSON for sales locations.

C **Caution:**
Use only genuine EPSON ink cartridges and do not refill them. Other products may cause damage not covered by EPSON's warranty.

Removing and Installing Ink Cartridges

Follow these steps to replace either or both ink cartridges:

1. Make sure the printer is on and one of the Ink Out lights is flashing or turned on.
2. Press the Pause button (check that the Pause light comes on).
3. Lower the output tray on the front of the printer and then lift up the printer's cover by the notches on its sides.

Warning:
W Never insert your hand in the paper path beneath the center of the cover; you may injure your hand.

4. Hold down the Alt button for about five seconds until the print head moves slightly left to the ink cartridge install position. The Pause light begins blinking. (The carriage returns to the home position after 30 seconds if the ink cartridges are not removed.)
5. Pull up the cartridge clamp to open it. The cartridge rises partially out of the printer.

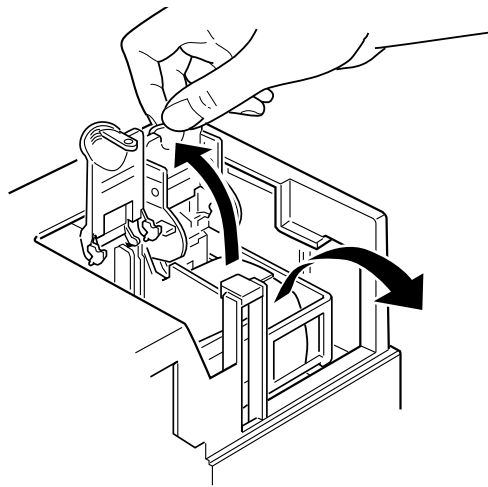

6. Lift the cartridge out of the printer and dispose of it carefully so any excess ink does not spill out. Do not take the used cartridge apart or try to refill it.

W **Warning:**
If ink gets on your hands, wash them thoroughly with soap and water. If ink gets into your eyes, flush them immediately with water.

7. Open the package containing the ink cartridge and remove the cartridge from its foil wrapper. Remove the tape seal from the top of the cartridge.

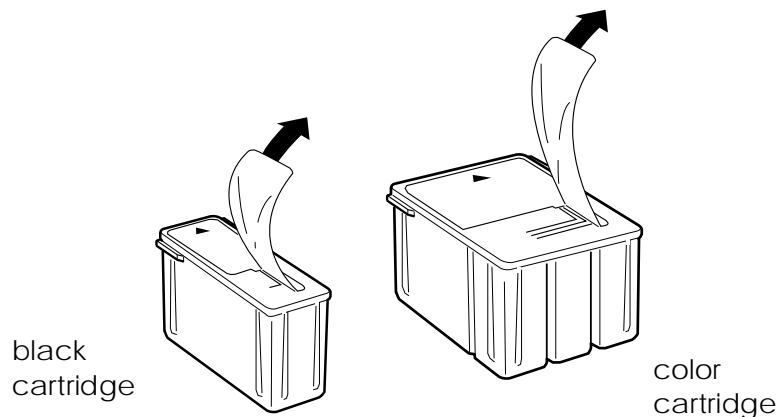

C **Caution:**
You must remove the tape seal from the top of the cartridge; leaving the tape on will permanently damage it. Do not remove the tape seal from the bottom of the cartridge; ink will leak out.

8. Lower the ink cartridge into its holder with the label facing up and the arrow pointing to the back of the printer.

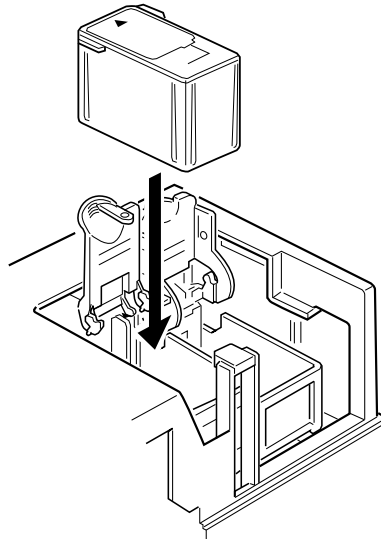

9. Push down the ink cartridge clamp until it locks in place.

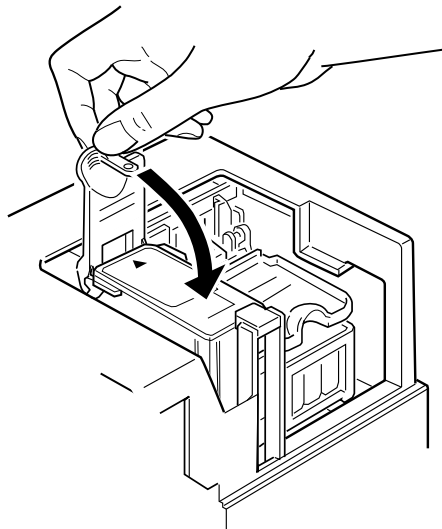

10. Press the Alt button again. The Pause light flashes as the printer charges the ink delivery system.
11. Close the printer cover. When the charging cycle finishes, the Pause light stops flashing and stays on. Press the Pause button to turn off the light and resume printing.

Cleaning the Printer

If you want to clean the printer, follow these steps:

1. Turn off the printer and disconnect any cables connected to it. Be sure to keep the printer cover closed as you clean it.
2. Remove any paper or other media from the sheet feeder.
3. Carefully clean away loose dust and dirt with a soft brush.
4. Clean the exterior with a soft cloth dampened in mild soap.
5. To clean ink out of the printer's interior, wipe it gently with a damp cloth.

Caution:

- Never use alcohol or thinner to clean the printer; these chemicals can damage the components and the printer case.*
- Do not use a hard or abrasive brush; these can scratch the printer surfaces.*
- Do not allow water to get on the printer mechanism or any electronic components.*
- Do not touch the gears inside the printer.*
- Do not spray inside the printer with lubricants or oils; they can damage the printer mechanisms.*

Transporting the Printer

If you need to transport your printer, follow these steps:

1. Press the Pause button and turn off the printer.
2. Open the printer cover and make sure that the print head is locked in the far right position. If it isn't, turn on the printer, wait about 10 seconds, and turn it off.

C **Caution:**
Do not remove the ink cartridges when transporting the printer. Transporting the printer without the cartridges installed can damage the printer.

3. Unplug the power cord from the electrical outlet.
4. Disconnect the interface cable from the printer.
5. Remove any paper from the sheet feeder and remove the paper support.
6. Push in the output tray extension and close the tray.
7. Install the transportation screw to secure the print head to the carriage as described in the sticker above the print head.
8. Attach any other protective materials to the printer. See the Notice Sheet that was packed with the printer.
9. Repack the printer and attachments in the original box.

Be sure to keep the printer flat as you transport it. If you notice problems with your printed output after transporting the printer, clean the print heads as described on page 3-2. If the image is misaligned, calibrate the printer as described in your *Setup and Software Guide* or as described below, if you are printing from DOS.

Calibrating the Printer When Printing from DOS

If vertical lines are misaligned when you print from DOS applications, you may need to calibrate the printer using its adjustment mode. To verify that your printer needs calibrating, print a demonstration page as instructed on page 2-7. Examine the demonstration printout; if vertical lines are misaligned, calibrate your printer. Do not calibrate your printer too often.

Follow these steps:

1. Make sure paper is load in the printer and turn it off.
2. Hold down the `Pause` button and turn on the printer to enter printer adjustment mode. It prints a multilingual instruction sheet.
3. Follow the instructions on the sheet to calibrate your printer.
4. When you are finished, press `Pause` and turn off the printer to exit printer adjustment mode.

When you turn on the printer and send your next print job, the lines should be aligned.

Chapter 4

Troubleshooting

Print Quality Problems	4-2
Problems with Printing	4-6
Paper Handling Problems	4-12
Paper Jam Problems	4-12
Paper Feeding Problems	4-12
Other Paper Handling Problems	4-13

This chapter describes what you can do if you are having problems printing. It is divided into these sections:

- ❑ **Print quality problems.** See this section if the print quality is not good or not what you expect.
- ❑ **Problems with printing.** See this section if your printer is having trouble printing.
- ❑ **Paper handling problems.** See this section if you have paper jams or other problems with paper handling.

If you have a printing problem, check the appropriate section and follow all suggestions that apply to your problem. Also check the ReadMe icon in the Windows EPSON group or on the Macintosh for the latest information. If none of the suggested solutions solve your problem, see “Where to Get Help” in the Introduction.

Print Quality Problems

To help you determine the nature of the problem, you may want to print a demonstration page and analyze elements on it. See Chapter 2 for instructions.

Print quality problems can often be solved by cleaning the print heads as described earlier in this chapter. Note that it may take as many as five cleaning cycles to solve a print quality problem. If cleaning the print heads does not improve the print quality, try the following:

- ❑ Check the status of the Ink Out 0 and Ink Out NNN lights to see whether the ink cartridges are low on ink. If so, replace the cartridges as described in Chapter 3.
- ❑ For color or complex grayscale images, turn on MicroWeave and turn off High Speed mode.

- ❑ Use a higher quality paper. For best print quality, use EPSON special coated papers for 360 and 720 dpi or EPSON high-quality glossy paper (720 dpi only).

Note:

Do not use high-quality glossy paper when you print at 360 dpi.

- ❑ Make sure the Media Type setting matches the type of paper or other media loaded in the printer.
- ❑ If you're printing a scanned image and the colors are not right, first try to fix the problem using your scanning software program.

If print quality does not improve, see the following specific problems.

Printed output is not what you expect or is faint or blurred.

You may not be printing on the correct side of the paper. Test both sides to determine which side gives you the best print quality. On coated paper, print only on the white coated side; on glossy paper or transparencies, print only with the cut corner facing the right side of the sheet feeder and remove each sheet as it is printed to prevent smearing by the next sheet.

Check that the paper thickness and thickness adjustment levers are set correctly for the media type. (See “Setting the Paper Thickness and Adjustment Levers” in Chapter 1 for more information.) Faint or blurred printouts can result if you print on plain paper or labels with these levers in incorrect positions.

Use a higher quality paper. Also, check that the Media Type setting in the driver is set for the type of paper or other media you loaded. If you are using 720-dpi resolution, you get better results when you use EPSON special coated paper for 720 dpi or EPSON high-quality glossy paper.

Check whether economy printing mode is on. To turn off this mode, press the Economy/Condensed button until the Economy light goes off.

Check whether your paper is moist or damp. Ink jet printers are sensitive to moisture absorbed by paper. Do not store paper in damp or humid places.

If you are printing color graphics at 360 or 720 dpi, make sure MicroWeave is on and High Speed mode is off. Also check that the Brightness and Contrast settings (PC driver) or Light/Dark setting (Macintosh driver) are appropriate for the image.

Try using the printer driver's Automatic feature to let the driver determine the appropriate image settings.

If you are using a DOS application and the black ink in the image is blurred, select Plain paper (composite black) using the Print Mode control panel button, as described in Chapter 2, and start the print job again.

Your Windows video driver may not be compatible with the printer. Use the standard Windows VGA driver or contact the manufacturer of your video card for an updated driver. For information on changing the video driver, see your Windows documentation.

Clean one or both print heads as described in Chapter 3.

Replace one or both ink cartridges.

Vertical or horizontal lines do not align.

Calibrate your printer as described in your *Setup and Software Guide*. If you are printing from DOS, see the instructions in this chapter.

You see white banding in your printouts.

Turn on MicroWeave in the printer driver.

If you still see white banding, clean the print heads as described earlier in the chapter.

The printout contains incorrect or garbled characters.

Make sure EPSON Stylus COLOR II is selected as the default Windows printer driver (PC driver) or is the last printer selected in the Chooser (Macintosh driver).

If you are running Windows, make sure the Print Manager is turned off in the Control Panel Printers utility; see your Windows documentation or online help for instructions.

Print jobs may be held in the EPSON Spool Manager (Windows) or the EPSON Monitor2 utility (Macintosh). Select any print jobs marked pending, waiting, or held; then select Delete or Cancel Printing.

If you still see incorrect or garbled characters, try printing a demonstration page to see if the problem is with your printer; see Chapter 2 for instructions. If the demonstration page prints, you may have a problem with your application software or your printer cable. Make sure your cable is connected securely and see your program's documentation for troubleshooting information. If no demonstration page prints, you may have a problem with your printer; contact your EPSON dealer or an authorized EPSON servicer.

You see incorrect colors in your printout.

Make sure EPSON Stylus COLOR II is selected as the default Windows printer driver (PC driver) or is the last printer selected in the Chooser (Macintosh driver).

Check that the printer driver's Brightness and Contrast settings (PC driver) or Light/Dark setting (Macintosh driver) are appropriate for the image.

If you scanned the image, the different color interpretation technologies used by your scanner, monitor, and printer can never produce an exact color match with the original image. However, check your scanner documentation for utilities you can use to calibrate your scanner to your monitor and printer to more closely match colors.

If you are printing from a DOS application using economy mode, black text or graphics will appear gray on your printout; turn off economy mode to achieve deeper blacks.

Printing starts too high or too low on the page, or the page length or margins are not what you expect.

Make sure you selected the correct Paper Size option in the printer driver; see your *Setup and Software Guide* for instructions.

Use your software program to adjust the margins, or change the number of lines per page, or change the page length setting to match the paper you are using.

Change the loading position of the paper using Default setting mode as described in Chapter 2.

Problems with Printing

If you cannot get the printer to print, first check that paper is loaded in the printer. Then check that the printer is plugged into a working electrical outlet that is not controlled by a switch or timer. Verify that the interface cable is securely connected to the printer and computer. If all this is correct, see the following specific problems.

Printing has stopped and the Pause light is on.

Printing is temporarily suspended. Press the Pause button to continue.

Printing has stopped but the Pause light is off.

One or both ink cartridges may be empty or too old. A cartridge is too old if it has been used longer than six months or beyond the date on its packaging. First clean the print heads as described earlier in this chapter. If this does not solve the problem, replace the ink cartridges.

C ***Caution:***
If you replace an ink cartridge before its Ink Out light flashes, the sensor that tells you when the ink is out will not work with the new cartridge.

If pressing the Pause button does not turn on the Pause light, turn off your printer and disconnect the interface cable. Then reconnect the cable and turn on the printer.

The cable between the printer and computer may not meet the specifications for the printer or computer. See “System Requirements” in your *Setup and Software Guide* for cable guidelines.

Turn off the printer and perform a self test as described in Chapter 1 of your *Setup and Software Guide*. If the self test does not print, the problem is with the printer. If the self test prints correctly, the problem is probably caused by your software.

The Ink Out 0 or Ink Out NNN light flashes or remains on and the printer does not print.

One or both ink cartridges are low on ink or empty; replace the indicated cartridge as described in Chapter 3.

All lights except the Power light flash and nothing prints.

Contact your dealer or your Authorized EPSON servicer.

Printing stops and the Data and Pause lights flash.

There is a problem with the carriage. Turn off the printer. After a few seconds, turn it back on and try printing again. If this does not solve the problem, contact your dealer or an authorized EPSON servicer.

You see a system memory error message on your PC and the printer does not print.

The Copies options in the Windows printer driver require additional system memory. If you see an error message or are unable to print using these options, try closing any unnecessary applications, reducing the size of your print job, turning off the Copies options, or increasing system memory.

The Windows printer driver installed with Windows 3.1 does not work correctly after you upgrade to Windows 95.

You need to reinstall the printer driver after upgrading to Windows 95 so the driver is set up correctly for Windows 95. See the *Setup and Software Guide for Windows* for instructions.

The printer sounds like it is printing, but nothing prints.

The print heads may need cleaning. See “Cleaning the Print Heads” in Chapter 3 for instructions.

One or both ink cartridges are empty or too old. A cartridge is too old if it has been used longer than six months or beyond the date on its packaging. First clean the print heads as described earlier in this chapter. If this does not solve the problem, replace the ink cartridges.

You see error messages on your PC because of printing conflicts.

Before sending print jobs to the printer, the EPSON Spool Manager stores them in a temporary directory. If you see conflict error messages or printing is very slow, the problem may be caused by other temporary files in this directory. To change the EPSON Spool Manager default directory, follow these steps:

1. Make a directory on your hard disk to store the Spool Manager files, for example, C:\SPLTEMP.
2. Open the EPSON program group and double-click the Spool Manager icon.
3. Make sure Epson Stylus Color II is selected, and then open the Queue menu.
4. Select Setup. In the Queue Setup dialog box, change the spool directory to the one you created in step 1.
5. Also make sure the Use Print Manager for this port checkbox is checked. Then select OK.
6. Open the Options menu and select Default Spool Directory.
7. In the dialog box, change the spool directory to the one you created in step 1. Then select OK.
8. Close the Spool Manager.

The printer prints blank pages.

Make sure EPSON Stylus COLOR II is selected as the default Windows printer driver (PC driver) or is the last printer selected in the Chooser (Macintosh driver).

Make sure you selected the correct Paper Size option in the printer driver; see your *Setup and Software Guide* for instructions. Also make sure the margins you selected in your application software fit the paper size you're using.

Text printing is slow.

You may be using printer driver settings that are more suitable for graphics printing and unnecessarily slowing down text printing. To speed up text printing only, turn off MicroWeave mode and turn on High Speed mode. Some combinations of Printing Mode (resolution) and Media Type do not allow you to select these settings; if this is the case for your settings, select a lower resolution, possibly using 180 dpi for drafts and 360 dpi for your final output. However, do not turn off MicroWeave when printing final copies of high-quality graphics or photographs.

If you're printing text from DOS applications and you selected composite black mode using the control panel Print Mode buttons, text printing will be much slower than true black printing. Select true black mode instead; see Chapter 2 for control panel instructions.

Ink cartridges do not last as long as expected.

The ink cartridge life depends on the amount of ink used in printing. If you often print pages with large graphics and dense text with little white space, you will use up cartridges faster than if you print pages with lots of white space. The printer also uses ink during a print head cleaning cycle, so do not perform cleaning cycles unless necessary.

If you replace an ink cartridge before its Ink Out light flashes, the sensor that tells you when ink is out will not work correctly with the new cartridge.

The printer does not seem to receive print jobs.

On a PC, release any print jobs that may be held in the EPSON Spool Manager. Start Spool Manager and click any job marked pending or held. Then open the Document menu and select Delete. Verify the EPSON Stylus COLOR II print queue is not held, open the Queue menu and click Hold if there is a checkmark beside the option.

On a Macintosh, release any print jobs that may be held in the EPSON Monitor2 utility. Click the upper right corner of the screen and select Monitor2 from the menu. Click any print job shown under Waiting and click Cancel Printing.

Make sure EPSON Stylus COLOR II is selected as the default Windows printer driver (PC driver) or is the last printer selected in the Chooser (Macintosh driver).

If you still get no output, try printing a demonstration page to see if the problem is with your printer; see Chapter 2 for instructions. If no demonstration page prints, you may have a problem with your printer; contact your EPSON dealer or an authorized EPSON servicer.

If the demonstration page prints, you may have a problem with your application software or your printer cable. Make sure your cable is connected securely and see your program's documentation for troubleshooting information. On a PC, you can use the printer's hex dump mode to pinpoint communication problems between the printer and a software program. To turn on hex dump mode, first turn off the printer. Then hold down the Load/Eject and Print Mode buttons, turn on the printer, and send a print job. The printer prints the exact codes it receives from the computer in hexadecimal format. Report the codes to your support technician.

Paper Handling Problems

This section describes how to prevent paper jams and ensure that paper feeds properly.

Paper Jam Problems

If paper jams inside the printer frequently, try the following:

- Use a higher quality paper that is suitable for ink jet printers and is not too thin, too thick, or rough. For best quality, use EPSON special coated and high-quality glossy papers. See Appendix A for paper specifications.
- Fan the stack of paper before you load it.
- If you loaded plain paper, try turning the stack over. The printable side may have been facing down.
- Do not load too many sheets in the sheet feeder. You can load up to 100 sheets of plain paper, 70 sheets of special coated paper, 10 envelopes, 50 sheets of transparency film (with one sheet of plain paper beneath the stack), or 30 sheets of high-quality glossy paper (with one sheet of plain paper beneath the stack).

Paper Feeding Problems

If paper does not feed properly, the most likely causes are:

- Paper is curled or folded. Use flat, undamaged paper.
- The paper is of poor quality; use a better quality paper.
- The paper is too thin or thick; see Appendix A for paper size and type specifications.

- ❑ The paper was exposed to excess humidity, over 60%. See Appendix A for specifications on required environmental conditions.
- ❑ The left edge guide is too tight or too loose; adjust it for the size of the paper.
- ❑ Too many sheets are loaded in the sheet feeder. You can load up to 100 sheets of plain paper, 70 sheets of special coated paper, 10 envelopes, 50 sheets of transparency film (with one sheet of plain paper beneath the stack), or 30 sheets of high-quality glossy paper (with one sheet of plain paper beneath the stack).

Other Paper Handling Problems

If you still have paper handling problems, see the following suggestions.

The printer loads more than one sheet at a time.

Remove the stack of paper and fan it. Tap it on a flat surface to even the edges. Then reload the paper.

The paper is too thin or thick, or was exposed to excess humidity; see Appendix A for exact specifications.

Make sure the paper thickness and thickness adjustment levers are set correctly for your media type; see Chapter 1 for instructions.

Make sure the printer driver's Copies setting and the copies setting in your application software are set to print one copy at a time. Also verify that you have selected the correct paper size in the driver and in your application software.

Ejected paper is wrinkled.

The paper is too thin or damp. Do not store paper in damp or humid places.

Single-sheet paper does not fully eject.

Use the Load/Eject button to eject the page.

The paper is too long. Use paper that is within the specified size. See Appendix A for exact specifications.

Paper is feeding crooked.

The paper is old or creased. Use only new, smooth sheets of paper.

Too much paper is loaded in the sheet feeder. Remove a few sheets.

The paper is not the proper size and quality; see Appendix A for exact specifications.

Appendix A

Technical Specifications



Printing	A-2
Paper	A-3
Ink Cartridges	A-5
Mechanical	A-6
Electrical	A-7
Environmental	A-7
Safety Approvals	A-7
Fonts	A-8
Interface Specifications	A-9
Parallel Interface	A-9
Serial Interface	A-11
Initialization	A-12
Default Settings	A-13

Printing

Printing method: On-demand ink jet

Nozzle configuration: 64 monochrome (black) nozzles
60 color (cyan, magenta, yellow) nozzles
(20 × 3; 20 for each color)

Printable columns and printing speed: *

Character pitch (characters per inch)	Printable columns	LQ printing speed (characters per second)
10	80	200
12	96	240
15	120	300
17 (10 condensed)	137	343
20 (12 condensed)	160	400

* Print speeds vary depending on system configuration, software application, resolution, and amount of page covered. Figures based on letter-size paper with color printing.

Resolution: Maximum 720 × 720 dpi

Paper feed speed: 92 milliseconds per 1/6-inch line

Input buffer: 56KB

Print direction: Bidirectional with logic seeking for text and graphics; unidirectional and autodirectional modes available in Default setting mode

Control code: ESC/P 2 and expanded raster graphics code
IBM X24/X24E emulation code

Paper feeding: Auto sheet feeder

Line spacing: 1/6-inch (default), 1/8-inch, or programmable
in 1/360-inch increments

Character tables: 1 Italic and 8 graphics character tables

Character sets: 1 legal and 14 International character sets

Paper

Note:

Since the quality of any particular brand or type of paper may be changed by the manufacturer at any time, EPSON cannot guarantee the use of any particular brand or type of paper. Always test samples of paper stock before purchasing large quantities or printing large jobs.

Paper path:	Sheet feeder, top entry
Sheet feeder capacity:	100 sheets of plain paper at 17 lb (64 g/m ²) 70 sheets of EPSON special coated paper 30 sheets of EPSON high-quality glossy paper (with one sheet of plain paper beneath the stack or each single sheet loaded) 50 transparency films (with one sheet of plain paper at bottom of stack) 10 envelopes

Paper sheets:

Size	Letter (8.5 × 11 inches) A4 (210 × 297 mm) Legal (8.5 × 14 inches) Statement (8.5 × 5.5 inches) Executive (7.5 × 10 inches)
------	---

Paper types	Plain paper, EPSON's Special coated paper, High-quality glossy paper, and transparencies
-------------	--

Thickness	0.003 to 0.004 inch (0.08 to 0.11 mm)
-----------	---------------------------------------

Paper weight	17 to 24 lb (64 to 90 g/m ²) Use 24 lb (90 g/m ²) paper under normal temperature and humidity conditions.
--------------	--

Envelopes:

Size	No. 10 9.5 × 4.1 inches (241 × 104 mm) DL 8.7 × 4.3 inches (220 × 110 mm)
------	--

Paper types	Plain, bond, or air mail paper
-------------	--------------------------------

Thickness	0.006 to 0.02 inch (0.16 to 0.52 mm)
-----------	--------------------------------------

Paper weight	12 to 24 lb (45 to 90 g/m ²)
--------------	--

Transparencies:

Size	A4	(210 × 297 mm)
	Letter	(8.5 × 11 inches)
Thickness	0.003 to 0.0033 inch (0.075 to 0.085 mm)	

Note:

- ❑ *Poor quality paper may reduce print quality and cause paper jams and other problems. If you encounter problems, switch to a higher grade of paper.*
- ❑ *Print on special coated paper, high-quality glossy paper, envelopes, and transparencies only under these normal conditions:*

Temperature: 59 to 77°F (15 to 25°C)

Humidity: 40 to 60% RH

(High-quality glossy paper can be stored at 20 to 60% relative humidity.)

- ❑ *Do not load folded or curled paper, envelopes, and transparencies.*
- ❑ *The following EPSON genuine papers are available:*
 - S041062 Special coated paper for 720 dpi printing (Letter)*
 - S041048 Special coated paper for 720 dpi printing (Legal)*
 - S041060 Special coated paper for 360 dpi printing (Letter)*
 - S041072 High-quality glossy paper (Letter)*
 - S041064 Transparency film (Letter)*

Printable area:

Single sheets

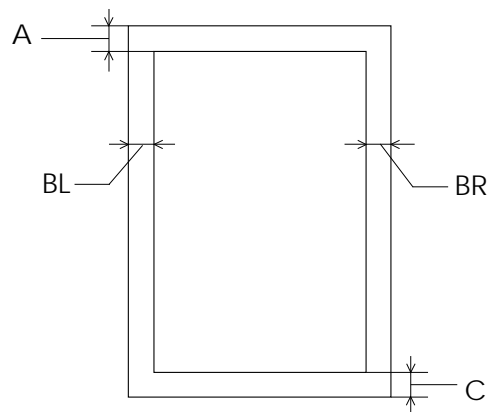

Envelopes

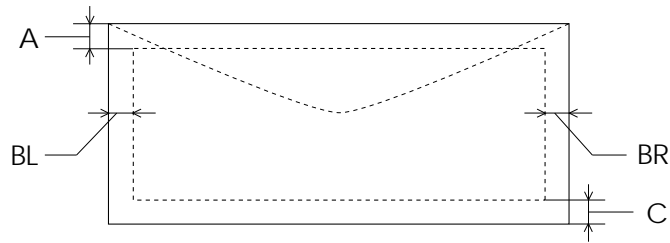

A The minimum top margin is 0.12 inch (3.0 mm).

Note: When printing multiple sheets of glossy paper, the minimum top margin is 1.2 inches (30 mm).

BL The minimum left margin is 0.12 inch (3.0 mm).

BR The minimum right margin is:

0.12 inch (3.0 mm) for Statement and Executive paper

0.38 inch (9.7 mm) for Letter and Legal paper and transparencies

0.15 inch (3.8 mm) for A4 paper

0.54 inch (13.8 mm) for DL envelopes

1.38 inch (35.1 mm) for #10 envelopes

C The minimum bottom margin is 0.54 inch (14.0 mm).

Ink Cartridges

Black ink cartridge (S020047):

Color	Black
Print capacity*	620 pages (A4 paper; text)
Cartridge life*	2 years from production date and up to 6 months after opening the package at 77°F (25°C)
Temperature	Storage: -4 to 104°F (-20 to 40°C) 1 month at 104°F (40°C) Transit: -22 to 140°F (-30 to 60°C) 1 month at 104°F (40°C) 120 hours at 140°F (60°C) Freezing:** 24.8°F (-4°C)
Dimensions	1.8 inches (W) × 2.3 inches (D) × 1.5 inches (H)

Color ink cartridge (S020049):

Colors	Cyan, magenta, and yellow
Print capacity*	320 pages (A4; 360 dpi; 5% of each color)
Cartridge life*	2 years from production date and up to 6 months after opening the package at 77°F (25°C)
Temperature	Storage: -4 to 104°F (-20 to 40°C) 1 month at 104°F (40°C) Transit: -22 to 140°F (-30 to 60°C) 1 month at 104°F (40°C) 120 hours at 140°F (60°C) Freezing:** 24.8°F (-4°C)
Dimensions	1.7 inches (W) × 2.2 inches (D) × 1.5 inches (H)

* Ink cartridge life may vary. If you often print large graphics and dense text with little white space, you use ink faster than if you print pages with lots of white space.

** The ink thaws in approximately 3 hours at 77°F (25°C).

- C** **Caution:**
- Use only genuine EPSON ink cartridges and do not refill them. Other products may cause damage not covered by EPSON's warranty.*
 - Do not use an ink cartridge after the expiration date on the package.*

Mechanical

Paper feed method:	Friction with auto sheet feeder, top entry
Total print volume:	75,000 pages (A4 paper; text)

Dimensions and weight:

Storage

Width 17.0 inches (433 mm)

Depth 9.8 inches (248 mm)

Height 7.8 inches (198 mm)

Weight 11.3 lb (5 kg), without ink cartridges

Printing

Width 17.0 inches (433 mm)

Depth 22.9 inches (582 mm)

Height 11.7 inches (297 mm)

Weight 11.3 lb (5 kg), without ink cartridges

Electrical

Input voltage range: 103.5 to 132 V

Rated frequency range: 50 to 60 Hz

Input frequency range: 49.5 to 60.5 Hz

Rated current: 0.5 A

Power consumption: Approx. 20 W (during self test, LQ at 10 cpi)

Environmental

Temperature: Operation 50 to 95°F (10 to 35°C)
Storage* -4 to 140°F (-20 to 60°C)
1 month at 104°F (40°C)
120 hours at 140°F (60°C)

Humidity: Operation 20 to 80% RH
Storage* 5 to 85% RH
(without condensation)

* Stored in shipping container

Safety Approvals

Safety standards: UL 1950 with D3, CSA 22.2 950 with D3

EMC: FCC part 15 subpart B class B

Fonts

The printer comes with an installed set of fonts, which are selectable using the Default setting mode. However, the printer always uses the fonts you select with your software program. The only time you need to select the printer's installed fonts is when your software program does not allow you to select fonts.

You can select other font and pitch combinations using ESC/P 2 commands, as described in Appendix B.

Bitmap fonts

Fonts	10 cpi	12 cpi	15 cpi	Proportional
EPSON Roman	√	√	√	√
EPSON Sans Serif	√	√	√	√
EPSON Courier	√	√	√	—
EPSON Prestige	√	√	√	—
EPSON Script	√	√	√	—

Scalable fonts

Fonts	Minimum point size	Maximum point size	Increments
EPSON Roman	8	32	2
EPSON Sans Serif	8	32	2
EPSON Roman T	8	32	2
EPSON Sans Serif H	8	32	2

Font samples

EPSON Roman-T	ABCDEFGHIJKLMN0123456789
EPSON Sans Serif H	ABCDEFGHIJKLMN0123456789
EPSON Roman	ABCDEFGHIJKLMN0123456789
EPSON Courier	ABCDEFGHIJKLMN0123456789
EPSON Sanserif	ABCDEFGHIJKLMN0123456789
EPSON Prestige	ABCDEFGHIJKLMN0123456789
EPSON Script	ABCDEFGHIJKLMN0123456789

Interface Specifications

Parallel Interface

Data format:	8-bit parallel, IEEE P1284 compatible mode
Synchronization:	$\overline{\text{STROBE}}$ pulse
Handshake timing:	BUSY and $\overline{\text{ACKNLG}}$ signals
Signal level:	TTL compatible
Connector:	36-pin, Centronics compatible connector

Pin assignments

Signal Pin	Return Pin	Signal	Direction	Description
1	19	$\overline{\text{STROBE}}$	IN	$\overline{\text{STROBE}}$ pulse to read data.
2	20	DATA 0	IN	These signals represent information in bits 0 to 7 of parallel data respectively. Each signal is at HIGH level when data is logical 1 and LOW when it is logical 0.
3	21	DATA 1	IN	
4	22	DATA 2	IN	
5	23	DATA 3	IN	
6	24	DATA 4	IN	
7	25	DATA 5	IN	
8	26	DATA 6	IN	
9	27	DATA 7	IN	
10	28	$\overline{\text{ACKNLG}}$	OUT	About a 5- μ s pulse. LOW indicates data has been received and the printer is ready to accept more data.
11	29	BUSY	OUT	A HIGH signal indicates the printer cannot receive data. The signal goes HIGH in the following cases: 1) During data entry (for each character) 2) During initialization 3) During self test, demonstration, and default-setting printing 4) During a printer-error state

Signal Pin	Return Pin	Signal	Direction	Description
12	28	PE	OUT	A HIGH signal indicates the printer is in a paper-out state or in an error state.
13	28	SLCT	OUT	Pulled up to +5 V through 1 k Ω resistance
14	30	$\overline{\text{AUTO FEED XT}}$	IN	When this signal is LOW, the paper is automatically fed one line after printing.
15	—	NC	—	Not used
16	—	GND	—	Logic ground level
17	—	CHASSIS GND	—	Printer's chassis ground, which is connected to the logic ground
18	—	Logic H	OUT	Pulled up to +5 V through 3.9 k Ω resistance
19-30	—	GND	—	Twisted-pair return signal ground level
31	30	$\overline{\text{INIT}}$	IN	When this signal goes LOW, the printer controller is reset to its state when the power is first turned on and the print buffer is cleared. This level is normally HIGH; its pulse width must be more than 50 μs at the receiving terminal.
32	29	$\overline{\text{ERROR}}$	OUT	This signal level goes LOW when the printer: 1) Is out of paper 2) Is in an error state 3) Has no ink cartridges installed
33	—	GND	—	Same as for Pins 19-30
34	—	NC	—	Not used
35	—	+5 V	OUT	Pulled up to +5 V through 3.3 k Ω resistance
36	30	SLIN	IN	Not used

Note:

- ❑ The column heading “Direction” refers to the direction of signal flow as viewed from the printer.
- ❑ “Return Pin” denotes the twisted-pair return pin to be connected at signal ground level. For the interface wiring, be sure to use a twisted-pair cable for each signal and to complete the connection on the return side.
- ❑ All interface conditions are based on TTL level. Both the rise and fall times of each signal must be less than 0.2 microseconds.
- ❑ Data transfer must be carried out by observing the $\overline{\text{ACKNLG}}$ or $\overline{\text{BUSY}}$ signal. Data transfer to this printer can be carried out only after receipt of the $\overline{\text{ACKNLG}}$ signal or when the level of the $\overline{\text{BUSY}}$ signal is LOW.

Timing chart

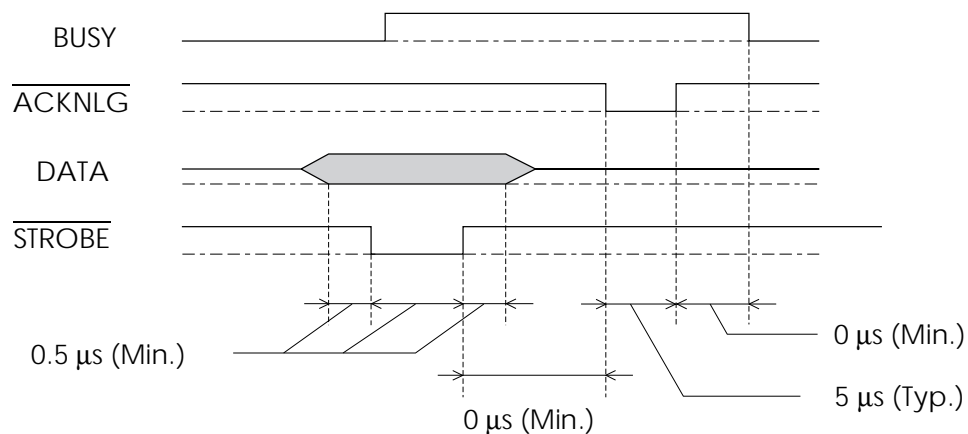

Transition time (the rise and the fall) of every signal must be less than 0.2 μs.

Serial Interface

The printer’s built-in serial interface is based on the RS-422 standard so you can connect the printer to an Apple Macintosh.

Standard:	Based on RS-422
Synchronization:	Asynchronous
Bit rate:	57.6 Kbps/230.4 Kbps
Handshaking:	DTR protocol

Word format:

Data bit	8 bits
Parity bit	None
Start bit	1 bit
Stop bit	1 bit

Connector: 8-pin mini-circular connector

Recommended cable: Apple System Peripheral-8 cable (M0197)

Initialization

The printer can be initialized (returned to a fixed set of conditions) in these ways:

Hardware initialization	<ul style="list-style-type: none">* The printer is turned on.* The printer receives an INIT signal from the parallel interface: pin 31 goes LOW
Software initialization	<ul style="list-style-type: none">* Software sends the ESC @ (initialize the printer) command; the last panel settings are kept
Control panel initialization	<ul style="list-style-type: none">* Hold down the Pause button and the Alt button; the last panel settings are kept

All three initialization methods reset the font according to the default settings selected using the control panel. However, ESC @ does not initialize the printer mechanism, clear the input data buffer, or clear the user-defined character set. The control panel initialization does not initialize the printer mechanism or clear the user-defined character set.

Default Settings

The table below shows the default settings that take effect when the printer is initialized.

Item	Default setting
Top-of-form position	Current paper position
Page length	Single sheets: 61 lines for letter-size paper 65 lines for A4-size paper
Left and right margins	Cancelled
Line spacing	1/6-inch line spacing
Character pitch	Last font selected in Default setting mode
Vertical tab position	Cleared
Horizontal tab positions	Every eight characters
Font selection	Last font selected in Default setting mode
Special printing effects	Cancelled (except condensed and economy printing)
User-defined character set	Hardware/control panel initialization: cleared Software initialization: deselected only

In addition, hardware and control panel initialization erases any text in the data buffer.

Appendix B

Commands and Character Tables

Command List B-2
 EPSON ESC/P 2 Commands B-2
 IBM X24/X24E Emulation Codes B-3

Character Tables B-4
 International Character Sets B-8
 Characters Available with ESC (^ Command B-9

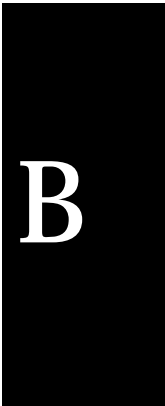

Command List

This printer works with the two sets of commands described in this section.

EPSON ESC/P 2 Commands

Select the EPSON ESC/P 2 printer commands in your software programs for the most advanced fonts and graphics available. If you need more information about using printer commands, you can purchase the *ESC/P 2 Reference Manual* (ESCP2REF) from EPSON Accessories by calling (800) 873-7766 (in the U.S. only). In Canada, call (800) BUY-EPSON for sales locations.

General operation:

ESC @, ESC U, ESC EM

Paper feeding:

CR, FF, LF, ESC 0, ESC 2, ESC 3, ESC +

Page format:

ESC (C, ESC C, ESC C 0, ESC Q, ESC I, ESC (c, ESC N, ESC O

Print position motion:

ESC \$, ESC \, ESC (V, ESC D, HT, ESC B, VT, ESC J

Font selection:

ESC k, ESC X, ESC P, ESC M, ESC g, ESC p, ESC x, ESC 4, ESC 5, ESC E,
ESC F, ESC !

Font enhancement:

SI, DC2, SO, ESC W, DC4, ESC w, ESC G, ESC H, ESC S, ESC T, ESC (-,
ESC -, ESC q

Spacing:

ESC SP, ESC (U, ESC c

Character handling:

ESC (t, ESC t, ESC R, ESC &, ESC :, ESC %, ESC 6, ESC 7, ESC (^

Bit image:

ESC *

Graphics:

ESC (G, ESC ., ESC (e

Color:

ESC r

Printing mode:

ESC (K

MicroWeave:

ESC (i

IBM X24/X24E Emulation Codes

This printer emulates the IBM Proprinter™ with the following commands. (For detailed information, see the IBM X24/X24E reference manual.)

General operation:

NUL, DC3, ESC j, BEL, CAN, DC1, ESC Q, ESC [K, ESC U

Paper feeding:

FF, LF, ESC 5, ESC A, ESC A (AGM*), ESC 0, ESC 1, ESC 2, ESC 3, ESC 3 (AGM*), CR

Page format:

ESC C, ESC X, ESC N, ESC O, ESC 4

Print position motion:

ESC d, ESC R, ESC D, HT, ESC B, VT, ESC J, ESC J (AGM*)

Font selection:

DC2, ESC P, ESC :, ESC E, ESC F, ESC I

Font enhancement:

DC4, SO, ESC SO, ESC W, ESC [@, SI, ESC SI, ESC G, ESC H, ESC T, ESC S, ESC -, ESC _

Spacing:

BS, SP, ESC [\

Character handling:

ESC 6, ESC 7, ESC [T, ESC ^, ESC \

Bit image:

ESC K, ESC L, ESC Y, ESC Z, ESC [g, ESC * (AGM*)

* Alternate Graphics Mode

Character Tables

The printer comes with an installed set of character tables. However, when printing from Windows and most DOS software programs, the printer prints the characters you see on screen and does not use its built-in character tables. Unless you're printing from a DOS program, and cannot print the character you need, you should never have to change the character table.

Note:

You never need to select the printer's character tables or fonts when using the printer with a Macintosh.

These character tables are selected using the printer's Default setting mode or by using software commands.

All tables except the italic are the same as the PC437 table for hex codes 00 through 7F, so only the PC437 table is shown completely. The rest of the tables show only the characters for hex codes 80 through FF.

PC437 (U.S., Standard Europe)

CODE	0	1	2	3	4	5	6	7	8	9	A	B	C	D	E	F
0	NUL		0	@	P	`	p	Ç	É	á			L	μ	α	≡
1			!	1	A	Q	a	q	ù	æ	í		⊥	⊥	β	±
2		DC2	"	2	B	R	b	r	é	Æ	ó		⊥	⊥	Γ	≥
3			#	3	C	S	c	s	ã	ô	ú		⊥	⊥	π	≤
4		DC4	\$	4	D	T	d	t	ä	ö	ñ		⊥	⊥	Σ	∫
5		S	%	5	E	U	e	u	à	ò	Ñ		⊥	⊥	o	∫
6			&	6	F	V	f	v	â	û	ø		⊥	⊥	μ	÷
7			'	7	G	W	g	w	ç	ù	Q		⊥	⊥	τ	≈
8			(8	H	X	h	x	ê	ÿ	z		⊥	⊥	φ	•
9	HT	EM)	9	I	Y	i	y	ë	Ö	ı		⊥	⊥	θ	·
A	LF		*	:	J	Z	j	z	è	Ü	ı		⊥	⊥	Ω	·
B	VT	ESC	+	;	K	[k	{	ı	φ	ı		⊥	⊥	δ	·
C	FF		,	<	L	\	l		ı	£	ı		⊥	⊥	ø	·
D	CR		-	=	M]	m	}	ı	¥	ı		⊥	⊥	ø	·
E	SO		.	>	N	^	n	~	ı	Å	ı		⊥	⊥	€	·
F	SI		/	?	O	_	o		ı	Å	f		⊥	⊥	ı	·

PC850 (Multilingual)

CODE	8	9	A	B	C	D	E	F
0	Ç	É	Á	⋯	Ł	Đ	Ó	—
1	Û	Æ	Í	⋯	ł	đ	ó	±
2	é	æ	ó	⋯	ł	đ	ó	±
3	â	ô	ú	⋯	ł	đ	ó	±
4	ä	ö	ñ	⋯	ł	đ	ó	±
5	à	ò	ñ	⋯	ł	đ	ó	±
6	â	û	æ	⋯	ł	đ	ó	±
7	ç	ÿ	ÿ	⋯	ł	đ	ó	±
8	è	ÿ	ÿ	⋯	ł	đ	ó	±
9	é	ÿ	ÿ	⋯	ł	đ	ó	±
A	è	ÿ	ÿ	⋯	ł	đ	ó	±
B	è	ÿ	ÿ	⋯	ł	đ	ó	±
C	è	ÿ	ÿ	⋯	ł	đ	ó	±
D	è	ÿ	ÿ	⋯	ł	đ	ó	±
E	è	ÿ	ÿ	⋯	ł	đ	ó	±
F	è	ÿ	ÿ	⋯	ł	đ	ó	±

PC860 (Portuguese)

CODE	8	9	A	B	C	D	E	F
0	Ç	É	Á	⋯	Ł	Đ	Ó	—
1	Û	Æ	Í	⋯	ł	đ	ó	±
2	é	æ	ó	⋯	ł	đ	ó	±
3	â	ô	ú	⋯	ł	đ	ó	±
4	ä	ö	ñ	⋯	ł	đ	ó	±
5	à	ò	ñ	⋯	ł	đ	ó	±
6	â	û	æ	⋯	ł	đ	ó	±
7	ç	ÿ	ÿ	⋯	ł	đ	ó	±
8	è	ÿ	ÿ	⋯	ł	đ	ó	±
9	é	ÿ	ÿ	⋯	ł	đ	ó	±
A	è	ÿ	ÿ	⋯	ł	đ	ó	±
B	è	ÿ	ÿ	⋯	ł	đ	ó	±
C	è	ÿ	ÿ	⋯	ł	đ	ó	±
D	è	ÿ	ÿ	⋯	ł	đ	ó	±
E	è	ÿ	ÿ	⋯	ł	đ	ó	±
F	è	ÿ	ÿ	⋯	ł	đ	ó	±

PC861 (Icelandic)

CODE	8	9	A	B	C	D	E	F
0	Ç	É	Á	⋯	Ł	Đ	Ó	—
1	Û	Æ	Í	⋯	ł	đ	ó	±
2	é	æ	ó	⋯	ł	đ	ó	±
3	â	ô	ú	⋯	ł	đ	ó	±
4	ä	ö	ñ	⋯	ł	đ	ó	±
5	à	ò	ñ	⋯	ł	đ	ó	±
6	â	û	æ	⋯	ł	đ	ó	±
7	ç	ÿ	ÿ	⋯	ł	đ	ó	±
8	è	ÿ	ÿ	⋯	ł	đ	ó	±
9	é	ÿ	ÿ	⋯	ł	đ	ó	±
A	è	ÿ	ÿ	⋯	ł	đ	ó	±
B	è	ÿ	ÿ	⋯	ł	đ	ó	±
C	è	ÿ	ÿ	⋯	ł	đ	ó	±
D	è	ÿ	ÿ	⋯	ł	đ	ó	±
E	è	ÿ	ÿ	⋯	ł	đ	ó	±
F	è	ÿ	ÿ	⋯	ł	đ	ó	±

PC863 (Canadian-French)

CODE	8	9	A	B	C	D	E	F
0	Ç	É	Á	⋯	Ł	Đ	Ó	—
1	Û	Æ	Í	⋯	ł	đ	ó	±
2	é	æ	ó	⋯	ł	đ	ó	±
3	â	ô	ú	⋯	ł	đ	ó	±
4	ä	ö	ñ	⋯	ł	đ	ó	±
5	à	ò	ñ	⋯	ł	đ	ó	±
6	â	û	æ	⋯	ł	đ	ó	±
7	ç	ÿ	ÿ	⋯	ł	đ	ó	±
8	è	ÿ	ÿ	⋯	ł	đ	ó	±
9	é	ÿ	ÿ	⋯	ł	đ	ó	±
A	è	ÿ	ÿ	⋯	ł	đ	ó	±
B	è	ÿ	ÿ	⋯	ł	đ	ó	±
C	è	ÿ	ÿ	⋯	ł	đ	ó	±
D	è	ÿ	ÿ	⋯	ł	đ	ó	±
E	è	ÿ	ÿ	⋯	ł	đ	ó	±
F	è	ÿ	ÿ	⋯	ł	đ	ó	±

PC865 (Nordic)

Abicomp

CODE	8	9	A	B	C	D	E	F
0	Ç	È	Á	·	L	⊥	α	≡
1	ü	æ	í	·	⊥	⊥	β	±
2	é	Æ	ó	·	⊥	⊥	Γ	≥
3	â	Ô	ú	·	⊥	⊥	Π	≤
4	à	ò	ñ	·	⊥	⊥	Σ	∫
5	â	ô	ñ	·	⊥	⊥	σ	∫
6	â	û	æ	·	⊥	⊥	μ	÷
7	ç	Û	Ω	·	⊥	⊥	τ	≈
8	è	ÿ	¿	·	⊥	⊥	ø	·
9	ë	Û	¿	·	⊥	⊥	ø	·
A	è	Û	¿	·	⊥	⊥	Ω	·
B	ï	ø	½	·	⊥	⊥	δ	·
C	ï	ø	½	·	⊥	⊥	ø	·
D	ï	ø	½	·	⊥	⊥	ø	·
E	Ë	Œ	«	·	⊥	⊥	È	·
F	Ë	Œ	«	·	⊥	⊥	È	·

CODE	8	9	A	B	C	D	E	F
0	MUL			Ò	ì	ò		
1			À	Ó	à	ó		
2		DC2	À	Ô	á	ô		
3			À	Õ	â	õ		
4		DC4	À	Ö	ä	ö		
5			À	Ø	å	ø		
6			Ç	Ù	ç	ù		
7			È	Ú	è	ú		
8			È	Ó	é	ó		
9	HT	EM	È	Ü	ë	ü		
A	LF		È	Ý	ë	ÿ		
B	VT	ESC	Ì	·	ì	·		
C	FF		Í	·	í	·		
D	CR		Í	·	í	·		
E	SO		Ï	·	ï	·		
F	SI		Ï	·	ï	·		DEL

BRASCII

CODE	8	9	A	B	C	D	E	F
0	MUL			·	À	Ð	à	ð
1			ì	±	À	Ñ	á	ñ
2		DC2	φ	±	À	Ò	â	ò
3			£	±	À	Ó	ã	ó
4		DC4	□	·	À	Ô	ä	ô
5			¥	μ	À	Õ	å	ö
6			·	¶	Æ	Ö	æ	ö
7			§	·	Ç	Ø	ç	ø
8			·	·	È	Ø	è	ø
9	HT	EM	·	·	È	Ù	é	ù
A	LF		·	·	È	Ú	ê	ú
B	VT	ESC	«	»	È	Ó	ë	û
C	FF		¿	¿	Í	Ü	ì	ü
D	CR		¿	¿	Í	Ý	í	ÿ
E	SO		¿	¿	Í	Þ	î	þ
F	SI		¿	¿	Ï	ß	ï	ÿ

Italic

CODE	8	9	A	B	C	D	E	F
0	NUL			0	@	P	`	p
1			!	1	A	Q	a	q
2		DC2	"	2	B	R	b	r
3			#	3	C	S	c	s
4		DC4	\$	4	D	T	d	t
5			%	5	E	U	e	u
6			&	6	F	V	f	v
7			'	7	G	W	g	w
8			(8	H	X	h	x
9	HT	EM)	9	I	Y	i	y
A	LF		*	:	J	Z	j	z
B	VT	ESC	+	;	K	[k	{
C	FF		,	<	L	\	l	;
D	CR		-	=	M]	m	}
E	SO		.	>	N	^	n	~
F	SI		/	?	O	_	o	

No characters are available for hex code 15 in the italic character table.

International Character Sets

You can select one of the following international character sets using the printer's Default setting mode or the ESC R command. For example, when you select "Italic France," the characters in the "France" row on the table below are used in the italic character table.

The following eight international character sets can be selected using Default setting mode or with the ESC R command.

Country	ASCII code hex											
	23	24	40	5B	5C	5D	5E	60	7B	7C	7D	7E
USA	#	\$	@	[\]	^	'	{		}	~
France	#	\$	à	°	ç	§	^	'	é	ù	è	¨
Germany	#	\$	§	Ä	Ö	Ü	^	'	ä	ö	ü	ß
UK	£	\$	@	[\]	^	'	{		}	~
Denmark	#	\$	@	Æ	Ø	Å	^	'	æ	ø	å	~
Sweden	#	¤	É	Ä	Ö	Å	Ü	é	ä	ö	å	ü
Italy	#	\$	@	°	\	é	^	ù	à	ò	è	ì
Spain	¤	\$	@	í	Ñ	¿	^	'	ñ	}	~	

The following seven additional sets can be selected only with the ESC R command.

Country	ASCII code hex											
	23	24	40	5B	5C	5D	5E	60	7B	7C	7D	7E
Japan	#	\$	@	[¥]	^	'	{		}	~
Norway	#	¤	É	Æ	Ø	Å	Ü	é	æ	ø	å	ü
Denmark II	#	\$	É	Æ	Ø	Å	Ü	é	æ	ø	å	ü
Spain II	#	\$	á	í	Ñ	¿	é	'	í	ñ	ó	ú
Latin America	#	\$	á	í	Ñ	¿	é	ü	í	ñ	ó	ú
Korea	#	\$	@	[₩]	^	'	{		}	~
Legal	#	\$	§	°	'	"	¶	'	©	®	†	™

Characters Available with ESC (^ Command

To print the characters in the table below, use the ESC (^ command.

CODE	0	1	7
0		▶	
1	☺	◀	
2	☹	↕	
3	♥	!!	
4	♦	¶	
5	♣		
6	♠	-	
7	•	⊥	
8	■	↑	
9	□	↓	
A	⊙	→	
B	♂	←	
C	♀	└	
D	♫	↔	
E	♫	▲	
F	⊙	▼	△

Glossary

auto line feed

When this feature is selected in the printer's Default setting mode, each carriage return code (CR) is automatically followed by a line feed (LF) code.

bidirectional printing

Printing in which the print head prints in both directions (bidirectionally). This increases print speed but may reduce precise vertical alignment. Also called *high speed printing*.

brightness

The lightness or darkness level of an image.

character table

The collection of letters, numbers, and symbols that constitute the set of characters used in a particular language.

CMYK

A method of specifying and creating colors using cyan (blue-green), magenta, yellow, and black (K).

condensed printing

Printing in which the width of each character is approximately 60% of the width of standard characters. Useful for fitting wide tables or spreadsheets onto the paper.

contrast

The range of difference between the darkest and lightest colors in an image. The greater the difference, the higher the contrast.

control code

A special code used to control a printer function such as performing a carriage return or line feed.

default

A value or setting that takes effect when the equipment is turned on, reset, or initialized.

dithering

A way of arranging dots on a page to simulate a shade or tone. See also *halftoning*.

dpi

Dots per inch. The dpi measures the resolution. See also *resolution*.

driver

See *printer driver*.

economy mode printing

Printing in which images are printed with fewer dots to save ink. Economy mode printing is faster, too.

error diffusion

A halftoning method where dot patterns are randomly distributed in an image to create soft edges.

ESC/P®

EPSON Standard Code for Printers. The system of commands sent by the computer to control the printer. It is standard for all EPSON printers and supported by most application software for personal computers.

ESC/P 2

Enhanced version of the ESC/P printer command language, including scalable fonts and enhanced graphics.

font

A style of type designated by a family name, such as Courier or Helvetica.™

grayscale

An image consisting of multiple shades of gray, ranging from white to black.

halftoning

Method of repeating tiny dot patterns to represent images.

hex dump

A troubleshooting feature that helps advanced users find the cause of communication problems between the printer and the computer. When the printer is in hex dump mode, it prints each code it receives in hexadecimal notation and ASCII characters. Also called data dump.

initialization

The process of restoring the printer's default settings (fixed set of conditions).

ink jet

A non-impact method of printing in which the printer produces each character by precisely spraying ink onto paper.

interface

The connection (via a cable) between the computer and the printer over which print data is transmitted to the printer.

media

Materials upon which data is printed such as envelopes, plain paper, special paper, transparency film, and index cards.

MicroWeave

A printing method in which images are printed in finer increments to reduce the possibility of banding and to produce laser-like images.

printable area

The area of a page on which the printer can print. It is smaller than the physical size of the page due to margins.

printer driver

A software program that sends commands for using the features of a particular printer.

reset

To return a printer to its defaults.

resolution

A measure of the amount of detail that can be represented. Resolution of printed images is measured in number of dots per inch (dpi). Your printer has three resolution settings: 720×720 , 360×360 , and 180×180 dpi.

RGB

A method of specifying color by its component proportion of red, green, and blue. Computer monitors use this method to represent colors.

unidirectional printing

Printing in which the print head prints in one direction only.

Unidirectional printing is useful for printing graphics because it allows precise vertical alignment.

Index

A

Accessories, purchasing, Intro-4, 3-4
Adjustment mode, 2-7, 3-10
AGM, *see* Alternate Graphics Mode
Aligning vertical lines, 2-7, 3-10
Alt button, 2-4-6, 3-2
Alternate Graphics Mode, 2-8
Apple Macintosh, Intro-1, 4-2
Auto carriage return, 2-8
Auto interface wait time, 2-8
Auto line feed, 2-8,
Auto sheet feeder, A-2-3, A-6

B

Banding, 4-5
BBS, *see* Bulletin Board Service
Bidirectional printing, 2-7,
Black ink cartridge, *see* Ink cartridges
Blurred images, 4-3-4
Bottom margin, 4-6, A-5
Brightness, G-1
Buffer, input, 2-5, A-2
Bulletin Board Service, Intro-5
Buttons, control panel, 2-2, 2-4-6

C

Cable, printer, 4-6-7
Calibrating the printer, 2-7, 3-10, 4-4
Carriage return, 2-8
Cartridges, *see* Ink cartridges
Character pitch, 2-7, A-13
Character tables
 available, A-2, B-4-7
 definition, G-1
 international, B-8
 selecting, 2-9

Cleaning

 buttons, 2-4-6
 print heads, 2-2, 2-4-5, 3-2-3
 printer, 3-8

CMYK, G-1

Coated papers

 loading, 1-7-10
 selecting, 1-2-3
 specifications, A-3-5

Color ink cartridge, *see* Ink cartridges

Commands

 ESC/P 2, B-2
 IBM X24/X24E, 2-8, B-3

CompuServe, Intro-5

Condensed

 button, 2-4-6
 light, 2-4
 mode, 2-2, 2-4
 printing, G-1

Contrast, G-1

Control code, A-2, G-1

Control panel, 2-2-5, 2-7

Copies setting, 4-13

Cord, power, 3-9

Customer support, Intro-3-5

D

Data light, 2-3

Default settings

 at initialization, 2-5, A-12-13
 mode, 2-2, 2-7-9

Demonstration page, 2-3, 2-6, 3-3, 4-2, 4-5, 4-11

Diffusion, error, G-2

Dimensions, printer, A-7

Dithering, G-1

DOS

 calibrating printer for, 2-7, 3-10
 printing from, 2-5

Dpi, A-2, G-2
Driver, *see* Printer, driver
Dump, *see* Hex dump mode

E

Economy
 button, 2-4-6, 3-2
 light, 2-3
 mode, 2-2-3, 4-4
 printing, G-2
Edge guide, *see* Left edge guide
Ejecting paper, 2-5
Electrical specifications, A-7
Electronic support services, Intro-4-5
Energy Star compliance, Intro-1-2
Energy, conserving, Intro-2
Envelopes
 loading, 1-7, 1-10,
 specifications, A-3-5
Environmental specifications, A-7
EPSON
 Accessories, Intro-4, 3-4
 America Forum, Intro-5
 Bulletin Board Service, Intro-5
 Customer Care Centers, Intro-3
 papers, 1-2-3, A-4
 Spool Manager, 4-5, 4-9, 4-11
Error diffusion, G-2
Error messages, 4-8-9
ESC (^ command, B-9
ESC @ command, A-12
ESC R command, B-8
ESC/P, G-2
ESC/P 2
 commands, 2-8, B-2
 definition, G-2

F

Factory defaults, 2-7
Faint images, 4-3-4
Fast printing, 2-7
Feeder, *see* Auto sheet feeder
Film, *see* Transparencies

Fonts
 built-in, 2-7
 condensed, 2-4
 default selection, A-13
 definition, G-2
 printing demonstration page, 2-6
 specifications, A-8

G

Glossy paper
 loading, 1-7-10
 selecting, 1-2-3
 specifications, A-3-4
Grayscale, 4-2, G-2

H

Halftoning, G-2
Heads, *see* Print heads
Help, where to get, Intro-3, Intro-5
Hex dump mode, 2-6, 4-11, G-2
High Speed mode, 4-2
Horizontal tab positions, A-13
Humidity
 for paper, 1-8, 4-13, A-3-4
 for printer, A-7

I

IBM X24/X24E commands, 2-8, B-3
Initialization, A-12-13, G-2
Ink cartridges
 conserving ink, 4-10
 empty, 3-3-4, 4-7-8
 life expectancy, 4-8, 4-10, A-5-6
 old, 4-7-8
 ordering, 3-4
 print capacity, A-5-6
 replacing, 2-4, 3-3-7, 4-8
 specifications, A-5-6
 tape seal, 3-6
Ink delivery system, charging, 3-7
Ink jet, A-2, G-3
Ink Out lights, 2-3, 3-3, 4-7

- Input buffer, 2-5, A-2
- Interface
 - cable, 4-6-7
 - definition, G-3
 - mode, 2-8
 - parallel, 2-8, A-9-11
 - serial, 2-8, A-11
 - specifications, A-9-12
 - wait time, auto, 2-8
- International character tables, B-8
- Internet, Intro-4

- J**
- Jammed paper, preventing, 4-12

- L**
- Left edge guide, 1-6-7, 1-9, 1-12, 4-13
- Left margin, A-5, A-13
- Levers
 - paper thickness, 1-3-4, 1-12, 4-3
 - thickness adjustment, 1-3-5, 1-12, 4-3
- Lights, control panel, 2-3-4, 4-7-8
- Line feed, auto, 2-8, G-1
- Line spacing, A-2, A-13
- Lines, aligning, *see* Vertical lines, aligning
- Load/Eject button, 2-5
- Loading
 - coated papers, 1-7-10
 - envelopes, 1-10, 1-12
 - glossy paper, 1-7, 1-10
 - transparencies, 1-7-10
- Loading position, adjusting, 2-9

- M**
- Macintosh, Intro-1, 4-2
- Maintenance, 3-2-8
- Manuals, how to use, Intro-2-3
- Margins
 - left and right, A-5, A-13
 - top and bottom, 2-9, 4-6, A-5
- Mechanical specifications, A-6-7
- Media Type, 4-3, G-3
- Messages, error, 4-8-9
- Microsoft Windows, Intro-1, 4-2
- MicroWeave, 4-2, G-3
- Monitor2 utility, 4-5, 4-11
- Moving the printer, *see* Transporting the printer

- N**
- Network interface mode, 2-9
- Notice sheet, 3-9
- Nozzles, print head, 3-2, A-2

- O**
- Online support, Intro-5
- Output tray, 1-6-7, 1-9

- P**
- Page length, A-13
- Paper
 - coated, 1-2-3, 1-9
 - ejecting, 2-5
 - envelopes, *see* Envelopes
 - feed speed, A-2
 - feeding problems, 4-12
 - glossy, *see* Glossy paper
 - handling, 1-2-10, 1-12, 4-12-14
 - jams, preventing, 4-12
 - ordering EPSON, 1-2-3, A-4
 - path, A-3
 - plain, 1-2, 1-5-7, A-3
 - printable area, A-4-5
 - printable surface, 1-5, 1-7, 1-10
 - selecting type, 1-2, 2-5
 - size, A-3
 - special, *see* Special papers
 - specifications, A-3-5
 - storing, 1-8, 4-4
 - thickness, A-3-4
 - transparencies, *see* Transparencies

Paper (*continued*)

- types, 1-2-3, 4-3, A-3-4
- weight, A-3
- wrinkled, 4-14
- Paper jams, 2-3, 4-12
- Paper Out light, 2-3
- Paper thickness lever, 1-3-4, 1-12, 4-3, 4-13
- Parallel interface, 2-8, A-9-11
- Pause
 - button, 2-4-5, 2-7
 - light, 2-4
- Pin assignments, A-9-11
- Pitch, character, 2-7, A-13
- Plain paper, 1-2, 1-5-7, A-3
- Power
 - consumption, A-7
 - cord, 3-9
 - light, 2-3
 - switch, 2-6-7
- Print direction, 2-7, A-2
- Print heads
 - cleaning, 2-4-5, 3-2-3
 - nozzles, 3-2, A-2
 - securing, 3-9
- Print Mode
 - button, 2-5-6
 - lights, 2-4
- Print quality
 - improving, 3-2-3
 - problems with, 4-2-6
- Print speed
 - increasing, 2-7
 - specifications, A-2
- Printable area, A-4-5, G-3
- Printable columns, A-2
- Printable surface, 1-5, 1-7, 1-10

Printer

- adjustment mode, 2-7, 3-10
 - buffer, 2-5, A-2
 - cable, 4-6-7
 - calibrating, 2-7, 3-10, 4-4
 - cleaning, 3-8
 - cleaning print heads, 2-2, 2-4, 3-2
 - controlling, 2-2, 2-4-6, 2-8-9
 - defaults, 2-7-9
 - dimensions, A-7
 - driver, Intro-1, 1-10-11, 4-5, 4-8-9, 4-11, G-3
 - hex dump mode, 2-6, 4-11, G-2
 - initializing, 2-5, A-12-13, G-2
 - pausing, 2-2, 2-4
 - problems with, 4-2-14
 - resetting, 2-2, 2-4
 - specifications, A-2-13
 - testing, 2-3, 2-6, 4-7
 - transporting, 3-9
 - weight, A-7
- ## Printing
- bidirectional, 2-7, G-1
 - demonstration page, 2-3, 2-6, 3-3, 4-2, 4-5, 4-11
 - fast, 2-7
 - method, A-2
 - problems with, 4-6-14
 - specifications, A-2
 - unidirectional, 2-7, G-3
- Problems, *see* Troubleshooting

Q

Quality, *see* Print quality

R

- ReadMe icon, Intro-1, 4-2
- Reset, 2-2, 2-4, G-3
- Resolution, A-2, G-3
- RGB, G-3
- Right margin, A-5, A-13

S

- Safety approvals, A-7
- Safety instructions, Intro-6
- Securing print heads, 3-9
- Self test, 2-3, 2-6, 4-7
- Serial interface, 2-8, A-11
- Service, Intro-3-5
- Sheet feeder, auto, A-2-3, A-6
- Spacing, line, A-2, A-13
- Special papers
 - loading, 1-7-10, 1-12
 - selecting, 1-2
 - specifications, A-3-5
- Special printing effects, A-13
- Specifications, A-2-13
- Speed, *see* Print speed
- Spool Manager, 4-5, 4-9, 4-11
- Support, online, Intro-5

T

- Tab positions, A-13
- Technical assistance, Intro-3-5, 4-2
- Telephone number, Intro-3
- Telephone numbers, Intro-5
- Temperature
 - for ink cartridges, A-5-6
 - for paper, 1-8, A-4
 - for printer, A-7
- Testing the printer, 2-3, 2-6, 4-7
- Thickness adjustment lever, 1-3-5, 1-12, 4-3, 4-13
- Timing chart, A-11
- Top margin, 2-9, 4-6, A-5
- Transparencies
 - loading, 1-7
 - selecting, 1-2, 1-8-10, A-3
 - specifications, A-3-4
- Transporting the printer, 3-9
- Troubleshooting, 2-6, 4-2-14

U

- Unidirectional printing, 2-7, G-3
- User-defined character set, A-13

V

- Vertical lines, aligning, 2-8, 3-10
- Vertical tab position, A-13

W

- Wait time, auto interface, 2-8
- Weight
 - paper, A-3
 - printer, A-7
- White banding, 4-5
- Windows, Intro-1, 4-2, 4-4-5, 4-8
- World Wide Web, Intro-4
- Wrinkled paper, 4-14